

Klemsan

KLEA 5 & POWYS 6 User Manual



SECTION 1

GENERAL INFORMATION

1.1 Features And Models	4
1.2 Correct Usage and Conditions For Safety	5
1.3 Front Panel	6
1.4 4 Quadrant Representation	7

SECTION 2

INSTALLATION

2.1 Preparation for Installation	8
2.2 Mounting	8
2.3 Wiring Wiring	10
2.3.1 Three-Phase Connection with Neutral (3P4W)	10
2.3.2 Three-Phase Connection without Neutral (3P3W)	10
2.3.2 Digital Output Connection Diagram	11
2.4 Dimensions	11

SECTION 3

MENUS

3.1 Measurements (Meas)	13
3.1.1 Instant Measurements (INSTANT)	14
3.1.2 Harmonic Values (HARM)	15
3.1.3 Energy Values (ENERGY)	16
3.1.4 Demand Values (DEMAND)	17
3.1.5 Min-Max Values (MIN-MA)	18
3.1.6 Input Counter (IN CNT)	19
3.1.7 General Counters (GE CNT)	19
3.1.8 Voltage-Current Unbalance Values (UNBLNC)	19
3.2 Settings (Set)	20
3.2.1 Communication Settings	20
3.2.2 Digital Output Settings (DO1 & DO2)	22
3.2.3 Digital Input Settings (DI1 & DI2)	23
3.2.4 Network Settings (NETWRK)	24
3.2.5 Demand Settings (DEMAND)	25
3.2.6 Alarm Settings (ALARM)	26
3.2.7 Device Settings (DEVICE)	27
3.2.8 Security Settings (SECURE)	28
3.2.9 Clear (CLEAR)	28
3.3 Info (Info)	29
3.4 Login (Login)	29

SECTION 4

RS485 COMMUNICATION

25

SECTION 5

FACTORY DEFAULT SETTINGS

46

SECTION 6 TECHNICAL SPECIFICATIONS

49

KLEA 5 & POWYS 6

SECTION 1
GENERAL
INFORMATION

1.1 Features and Models

KLEA 5 and POWYS 6 series devices can be used to measure electrical parameters like current, voltage, frequency, harmonic, etc. in 3-phase systems. Devices have the following features optionally.

- RS485 (Modbus RTU) and Ethernet (Modbus TCP) Communication Interfaces
- Gateway Function
- Energy Meters
- 3 Tariffs
- Ability to store minimum, maximum and demand values
- Run hour, on hour and power interruption counters
- Digital Input/Output
- Alarm Relay Output
- Indication for phase loss and phase sequence at current and voltage inputs
- THDV, THDI
- Up to 31 current and voltage odd harmonics

Product Name		POWYS 606R	KLEA 500R	KLEA 506R	
Stock Name		606604	606703	606704	
Connection Types		3P3W - 3P4W	3P3W - 3P4W	3P3W - 3P4W	
ÖLÇÜM	CLASS (IEC 61557-12)	Class 0,5	Class 0,5	Class 0,5	
	Power	Active Power	√	√	√
		Reactive Power	√	√	√
		Apparent Power	√	√	√
	Electrical Parameters	Current	√	√	√
		Voltage	√	√	√
		Frequency	√	√	√
	Quality Parameters	THDV-THDI	√	√	√
		True Power Factor (pF)	√	√	√
		Displacement Power Factor (cos Ø)	√	√	√
Demand	√	√	√		
Max/Min	√	√	√		
Voltage/Current Unbalance		√	√	√	
Phase Sequence, Phase Loss		√	√	√	
Screen		Custom LCD	Custom LCD	Custom LCD	
Counters	On Hour	√	√	√	
	Run Hour	√	√	√	
	Power Interruption	√	√	√	
Alarm		√	√	√	
Alarm Output		2R0	-	2R0	
Communication	RS485 (Modbus RTU)	√	√	√	
	Ethernet (Modbus TCP)	-	-	-	
Gateway Function		-	-	-	
Digital Input		2DI	-	2DI	
Digital Output		2DO	-	2DO	
Energy Measurement		√	√	√	
4 Quadrant Reactive Energy Measurement		√	√	√	
Tariff		3	-	3	
Harmonics		31st	31st	31st	

Product Name		KLEA 500RE	KLEA 506RE	KLEA 516RE	
Stock Name		606707	606708	606709	
Connection Types		3P3W - 3P4W	3P3W - 3P4W	3P3W - 3P4W	
ÖLÇÜM	CLASS (IEC 61557-12)	Class 0,5	Class 0,5	Class 0,5	
	Power	Active Power	√	√	√
		Reactive Power	√	√	√
		Apparent Power	√	√	√
	Electrical Parameters	Current	√	√	√
		Voltage	√	√	√
		Frequency	√	√	√
	Quality Parameters	THDV-THDI	√	√	√
		True Power Factor (pF)	√	√	√
		Displacement Power Factor (cos \emptyset)	√	√	√
Demand	√	√	√		
Max/Min	√	√	√		
Voltage/Current Unbalance		√	√	√	
Phase Sequence, Phase Loss		√	√	√	
Screen		Custom LCD	Custom LCD	Custom LCD	
Counters	On Hour	√	√	√	
	Run Hour	√	√	√	
	Power Interruption	√	√	√	
Alarm		√	√	√	
Alarm Output		-	2RO	2RO	
Communication	RS485 (Modbus RTU)	√	√	√	
	Ethernet (Modbus TCP)	√	√	√	
Gateway Function		-	-	√	
Digital Input		-	2DI	2DI	
Digital Output		-	2DO	2DO	
Energy Measurement		√	√	√	
4 Quadrant Reactive Energy Measurement		√	√	√	
Tariff		-	3	3	
Harmonics		31st	31st	31st	







1.2 Correct Usage and Conditions For Safety

- Installation and wiring must be performed by authorized technicians in accordance with the instructions in the user manual. Do NOT commission the device before proper wiring.
- Make sure the device is de-energized before connecting to the mains.
- Short-circuit the k-I terminals of the current transformer in another location before disconnecting the current transformers. Failing to do so will cause dangerously high voltages in the secondary terminals of the current transformers.
- Use a dry cloth to clean the device. Do NOT use alcohol, thinner, or any abrasive materials.
- Make sure all wiring is properly made before commissioning the device.
- Do NOT open the device. There are no serviceable parts by the user.
- Keep the device away from humidity, water, vibrations, and dust.
- It is advisable to connect a circuit breaker or an automatic fuse between the current input of the device and the mains (2 amps).



The manufacturer does NOT assume any responsibility for any undesired consequences if the above measures are NOT adhered to.

1.3 Front Panel

-  ➔ It is used to show the screen where settings are not allowed.
-  ➔ Indicates the communication status. The down arrow means that the query is transmitted to the device, and the up arrow means that data is received from the device.
-  ➔ It shows the current and voltages connected to the device. It represents the 1st Phase, 2nd Phase, and 3rd Phase, respectively.
-  ➔ When the digital outputs are active, the relevant icon is active.
-  ➔ Indicates that the device is in an error state.
- Only exclamation ➔ Current direction reversed.
- Only triangular frame ➔ Phase sequence error
- Exclamation + Frame ➔ Pulse Error
-  ➔ It is active when the device is in an alarm state. Alarm assignments can be made to the following parameters.
 - Voltage
 - Current
 - Frequency
 - Active Power
 - Reactive Power
 - Apparent Power
 - Power Factor
-  ➔ Indicates the active relay.



1.4 – 4 Quadrant Representation

The angle (\emptyset) between voltage and current provides us information about the direction of energy flow. A positive sign for active/reactive power indicates that active/reactive power is consumed. And also a negative sign for active/reactive power indicates that active/ reactive power is generated.

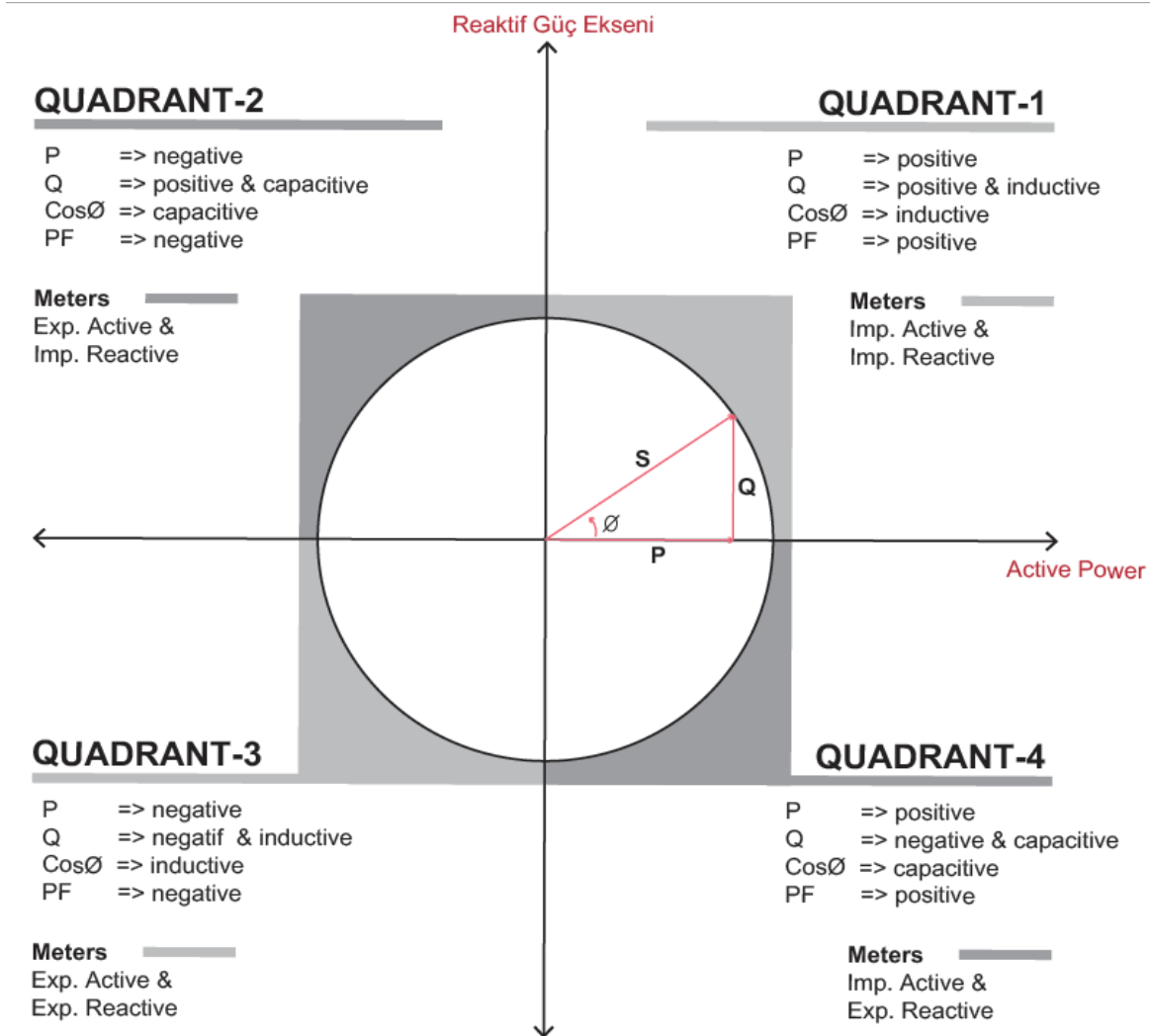

! If the signs of active and reactive power are examined, it can be defined the quadrant that Klea measures.

e.g.;

P= +10 kW, Q = +5 kVAr → Quadrant-1

P= -10 kW, Q = +5 kVAr → Quadrant-2

P= -10 kW, Q = -5 kVAr → Quadrant-3

P= +10 kW, Q = -5 kVAr → Quadrant-4

KLEA 5 & POWYS 6

SECTION 2
INSTALLATION

2.1 Preparation for Installation

The purchased device may not include all hardware options referred in this document. This situation does not constitute an impediment to the electrical installation.

! Assembly and related connections of KLEA, must be implemented by authorized persons in accordance with the instructions of user manual.
The device must not be put into service if the operator is not sure that all connections are correctly accomplished.

2.2 Mounting

Device is placed vertically into the gap located in the panel.

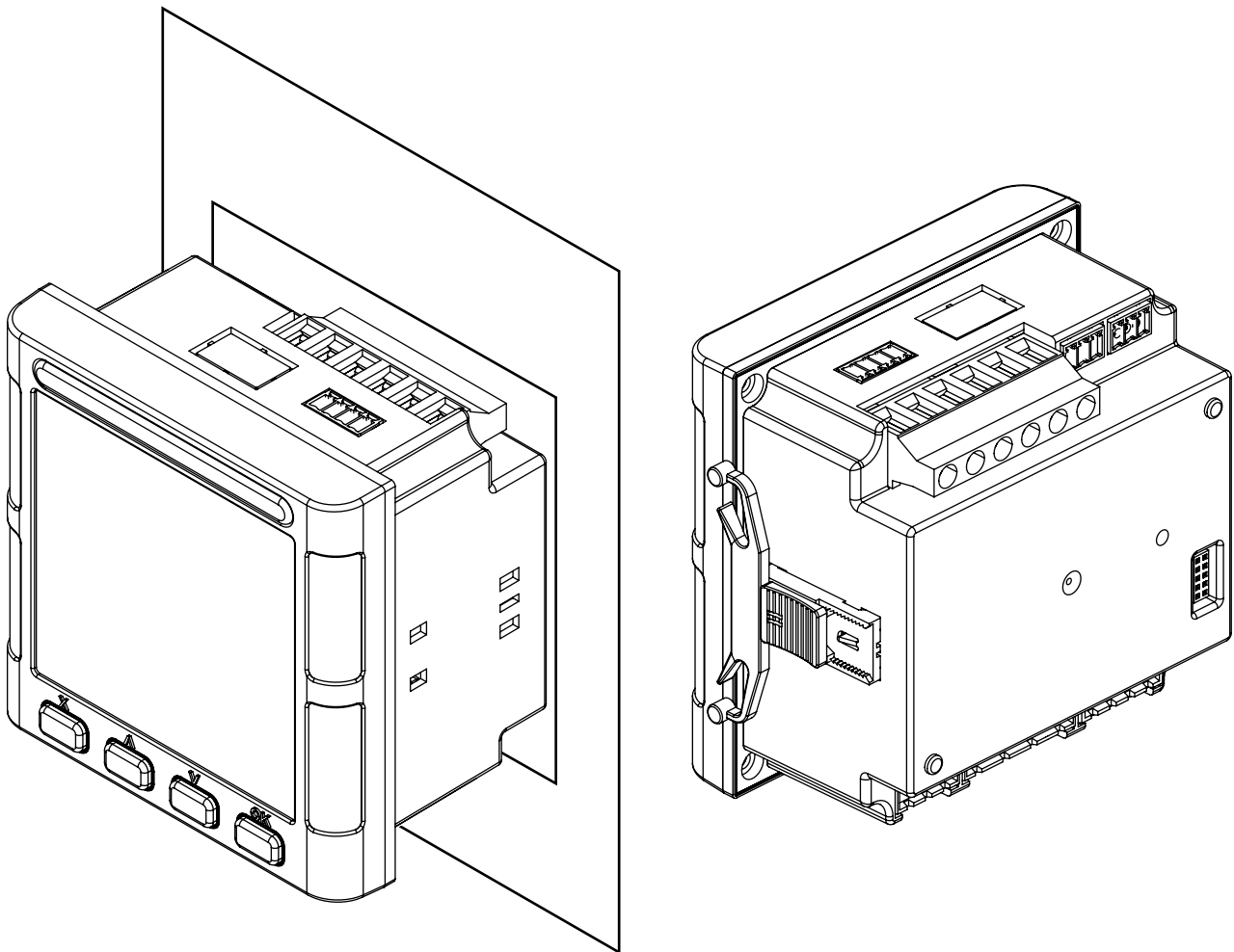

After the device is placed into the panel, fixing brackets should be installed. Then the device is fixed to the panel by pushing the fixing brackets on the panel.

POWYS 6 series devices are used by placing them on a standard 35mm rail.

! Before wiring up voltage and current ends to KLEA, you must be sure that the power is cut.

! Before disconnecting current transformer leads, be sure that they are short circuited elsewhere or connected to a parallel load which has sufficiently low impedance. Otherwise dangerously high voltages will be induced at the current transformer leads. Same phenomena also apply for putting into service.

2.3 Wiring Wiring

2.3.1 Three-Phase Connection with Neutral (3P4W)

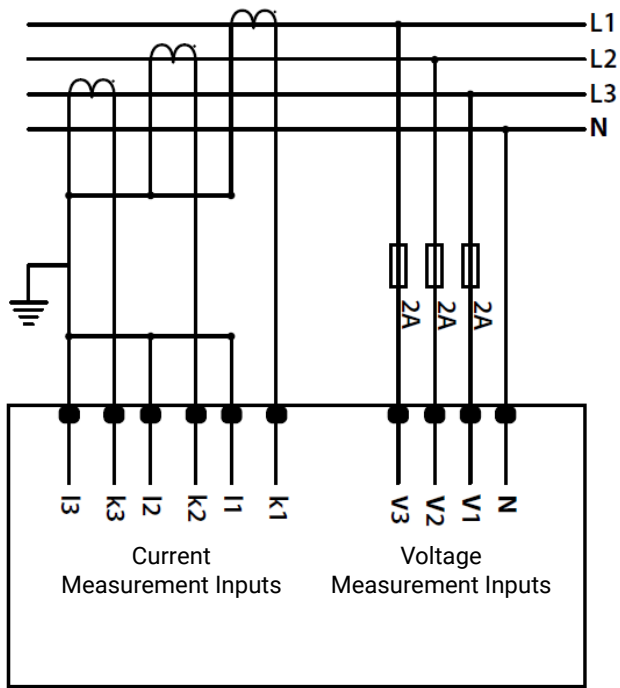

Figure 1 3P4W Connection

2.3.2 Three-Phase Connection without Neutral (3P3W)

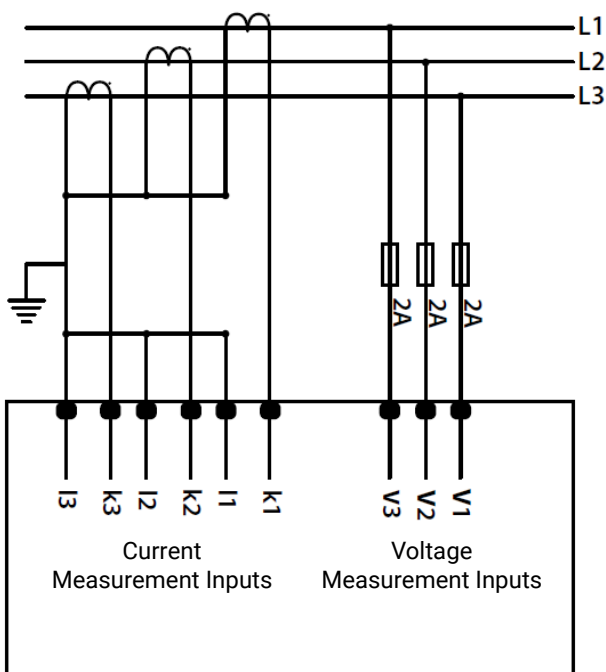
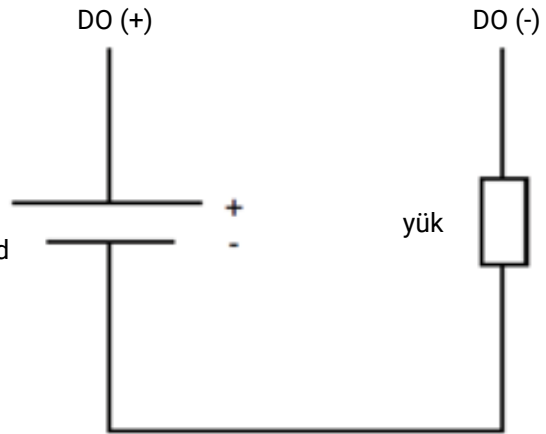

Figure 2 3P3W Connection

2.3.3 Digital Output Connection Diagram

External DC Power Supply must be connected
(5-30V DC)



2.4 Dimensions

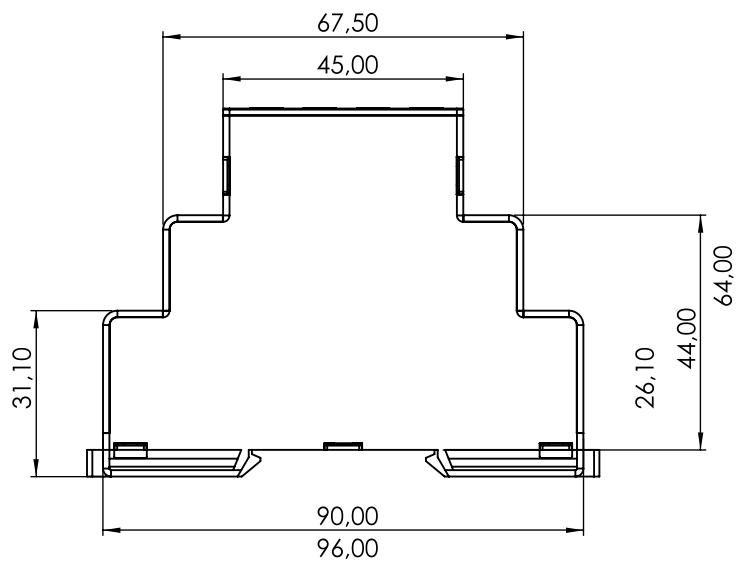
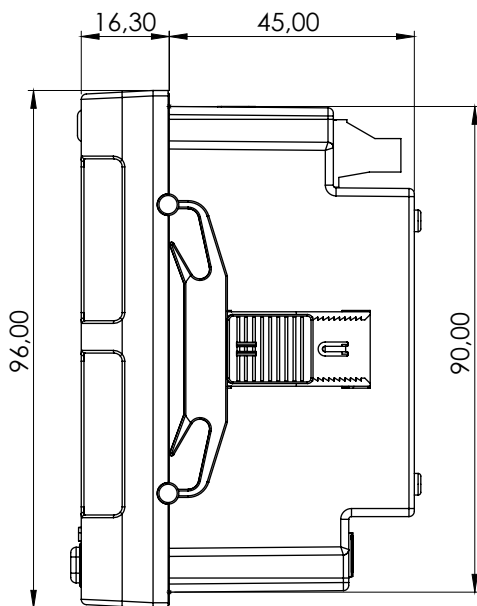
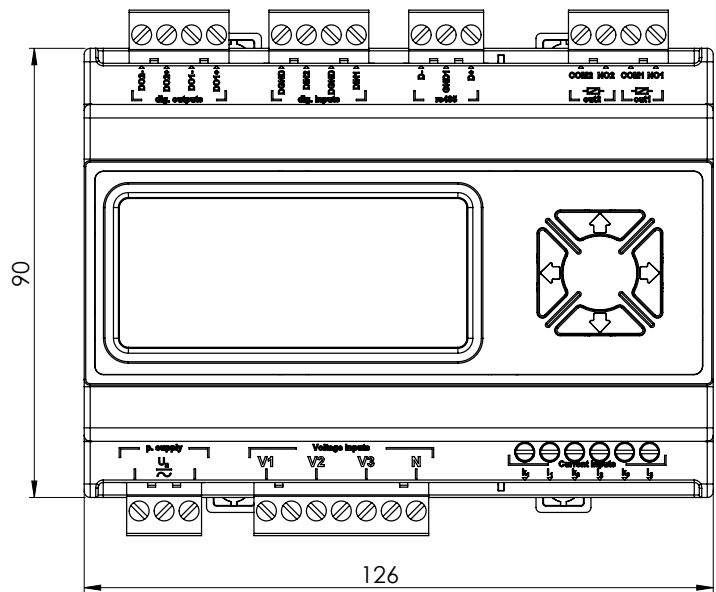
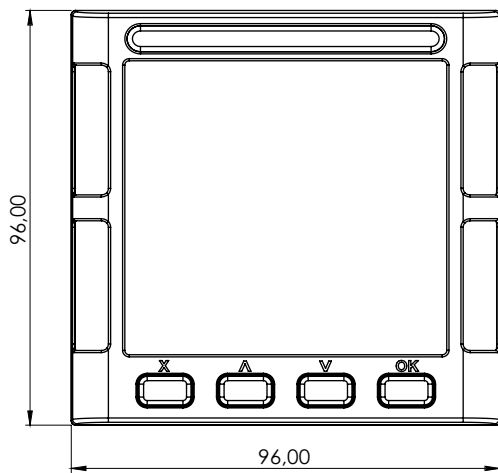

KLEA 5 & POWYS 6

SECTION 3
MENUS

There are 4 main menus in the devices: MEASUREMENTS (MEAS), SETTINGS (SET), DEVICE INFO (INFO), and LOGIN (LOGIN).

MAIN MENU	MEASUREMENTS (MEAS)	↕ OK X
	↓	
	SETTINGS (SET)	↕ OK X
	↓	
	INFO (INFO)	↕ OK X
	↓	
	LOGIN (LOGIN)	↕ OK X



The “OK”, button is used to enter the submenus and the “X” button is used to exit back. Switching between menus and submenus is done with the “Λ” and “V” buttons.

! The menu structure above may vary in different models.

3.1 MEASUREMENTS (MEAS)

Under this tab, there are instant measurements, harmonic values, energy values, demand values, min-max values, counters and voltage-current unbalance.

MEASUREMENTS (MEAS)	Instant Measurements (INSTAN)	↕ OK X
	↓	
	Harmonic Values (HARM)	↕ OK X
	↓	
	Energy Values (ENERGY)	↕ OK X
	↓	
	Demand Values (DEMAND)	↕ OK X
	↓	
	Min-Max Values (MIN-MA)	↕ OK X
	↓	
	Input Counters (IN CNT)	↕ OK X
	↓	
General Counters (GE CNT)	↕ OK X	
↓		
Unbalance (UNBLNC)	↕ OK X	

! The menu structure above may vary in different models.

3.1.1 Instant Measurements (INSTANT)

The following parameters and the average, total, minimum, and maximum values of these parameters (depending on the parameter) are also shown on the instant measurements menu.

- Voltage (phase- neutral, phase - phase)
- Current
- Neutral current
- Frequency
- Active Power
- Reactive Power
- Apparent Power
- Power Factor
- Cos Ø
- Total Harmonic Distortion for Voltage
- Total Harmonic Distortion for Current

Switching between parameters is done with “Λ” and “V” buttons.

MEASUREMENTS (MEAS)	Instant Measurements (INSTANT)	INSTANT VLN (VLN)	OK X	AVERAGE VLN (AVG)
		↓		
		INSTANT VLL (VLL)	OK X	AVERAGE VLL (AVG)
		↓		
		INSTANT CURRENT (I)	OK X	TOTAL (TOTAL)
		↓		
		INSTANT NEUTRAL CURRENT (IN)	OK X	
		↓		
		INSTANT FREQUENCY (F)	OK X	
		↓		
		INSTANT ACTIVE POWER (P)	OK X	TOTAL (TOTAL)
		↓		
		INSTANT REACTIVE POWER (Q)	OK X	TOTAL (TOTAL)
		↓		
INSTANT APPARENT POWER (S)	OK X	TOTAL (TOTAL)		
↓				
INSTANT POWER FACTOR (PF)	OK X	TOTAL (TOTAL)		
↓				
INSTANT COSØ (PF)				
↓				
INSTANT THDV (THDV)				
↓				
INSTANT THDI (THDI)				

! The menu structure above may vary in different models. The units of the parameter displayed are shown on the right side of the screen.



Phase 1, Phase 2, and Phase 3 values (V12, V23, and V31 for VLL voltage) are shown on the screen from top to bottom, respectively.

3.1.2 Harmonic Values (HARM)

In the harmonic data menu, individual harmonic values of current and voltage parameters are displayed. Up to 31 single harmonic data are measured in the device.

MEASUREMENTS (MEAS)	→ OK ↵ X	Harmonic Values (HARM)	→ OK ↵ X	Voltage Harmonics (VLTAGE)	→ OK ↵ X	Phase 1(Ph1)	↵ OK X	1..31 Odd Harmonics
				↓				
				Phase 2(Ph2)	↵ OK X	1..31 Odd Harmonics		
				↓				
				Phase 3(Ph3)	↵ OK X	1..31 Odd Harmonics		
				↓				
				Phase 1(Ph1)	↵ OK X	1..31 Odd Harmonics		
				↓				
				Phase 2(Ph2)	↵ OK X	1..31 Odd Harmonics		
				↓				
Phase 3(Ph3)	↵ OK X	1..31 Odd Harmonics						

3.1.3 Energy Values (ENERGY)

Under this menu, there are meters for the following energy parameters.

- Import Active Energy
- Export Active Energy
- Import Reactive Energy
- Export Reactive Energy

Devices with Digital Input have 3 different tariffs. Tariff configuration are explained under [3.2.3 Digital Input Settings \(DI1 & DI2\)](#).

MEASUREMENTS (MEAS)	Energy Values (ENERGY)	TOTAL	↵ OK X	Import Active Energy (Total) (Wh)	↵ OK X	Import Active Energy (3 phase)(Wh)		
				↓				
				Export Active Energy (Total) (Wh)	↵ OK X	Export Active Energy (3 phase)(Wh)		
				↓				
				Import Reactive Energy (Total)(VArh)	↵ OK X	Import Reactive Energy (3 phase)(VArh)		
				↓				
				Export Reactive Energy (Total)(VArh)	↵ OK X	Export Reactive Energy (3 phase)(VArh)		
				↓				
				T1	↵ OK X	Import Active Energy (Total) (Wh)	↵ OK X	Import Active Energy (3 phase)(Wh)
				↓				
				Export Active Energy (Total) (Wh)	↵ OK X	Export Active Energy (3 phase)(Wh)		
				↓				
				Import Reactive Energy (Total)(VArh)	↵ OK X	Import Reactive Energy (3 phase)(VArh)		
				↓				
				Export Reactive Energy (Total)(VArh)	↵ OK X	Export Reactive Energy (3 phase)(VArh)		
				↓				
				T2	↵ OK X	Import Active Energy (Total) (Wh)	↵ OK X	Import Active Energy (3 phase)(Wh)
				↓				
				Export Active Energy (Total) (Wh)	↵ OK X	Export Active Energy (3 phase)(Wh)		
				↓				
Import Reactive Energy (Total)(VArh)	↵ OK X	Import Reactive Energy (3 phase)(VArh)						
↓								
Export Reactive Energy (Total)(VArh)	↵ OK X	Export Reactive Energy (3 phase)(VArh)						
↓								
T3	↵ OK X	Import Active Energy (Total) (Wh)	↵ OK X	Import Active Energy (3 phase)(Wh)				
↓								
Export Active Energy (Total) (Wh)	↵ OK X	Export Active Energy (3 phase)(Wh)						
↓								
Import Reactive Energy (Total)(VArh)	↵ OK X	Import Reactive Energy (3 phase)(VArh)						
↓								
Export Reactive Energy (Total)(VArh)	↵ OK X	Export Reactive Energy (3 phase)(VArh)						



3.1.4 Demand Values (DEMAND)

In the demand values menu, the average values of current and power values during the set demand period and the maximum values of these values are displayed.

MEASUREMENTS (MEAS)	↵ OK ⏪ X	Demand Values (DEMAND)	↵ OK ⏪ X	Previous Demand (PREV)	↵ OK ⏪ X	Current Demand (Total)	↵ OK ⏪ X	Current Demand (3 phase)	
						↓	Import Active Power Demand (Total)	↓	Export Active Power Demand (Total)
						↓	Import Reactive Power Demand (Total)	↓	Export Reactive Power Demand (Total)
						↓	Apparent Power Demand (Total)		
						↓	Current Demand (Total)	↵ OK ⏪ X	Current Demand (3 phase)
						↓	Import Active Power Demand (Total)	↓	Export Active Power Demand (Total)
						↓	Import Reactive Power Demand (Total)	↓	Export Reactive Power Demand (Total)
						↓	Apparent Power Demand (Total)		
						↓	Maximum Demand (MAX)	↵ OK ⏪ X	
						↓	Current Demand (Total)	↵ OK ⏪ X	Current Demand (3 phase)
						↓	Import Active Power Demand (Total)	↓	Export Active Power Demand (Total)
						↓	Import Reactive Power Demand (Total)	↓	Export Reactive Power Demand (Total)
						↓	Apparent Power Demand (Total)		

In the PREV menu, previous demand values of the following parameters are calculated at the end of the previous demand period. In the MAX menu, the maximum demand values of the following parameters are calculated since the device was energized.

- Current Demand (Total and 3 phase)
- Import Active Power Demand (Total)
- Export Active Power Demand (Total)
- Import Reactive Power Demand (Total)
- Export Reactive Power Demand (Total)
- Apparent Power Demand (Total)

As an example, the graph below shows the averages (previous demand) and the max demand values of the current signal for the 15-minute demand period.

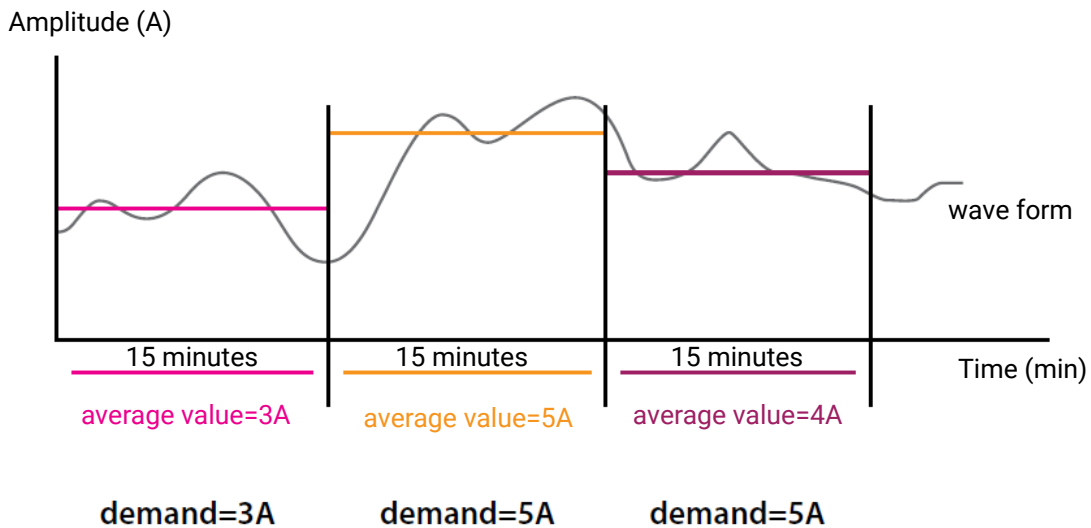

* demand period= 15 mins.

Switching between parameters is done with the "A" and "V" buttons.

3.1.5 Min-Max Values (MIN-MA)

Bu menü altında cihazda ölçülen aşağıdaki parametrelerin cihaz ilk açıldığı andan itibaren ölçülen minimum ve maksimum veriler gösterilmektedir.

- Voltage (LN) (Average and 3 phase)
- Voltage (LL) (Average and 3 phase)
- Current (Total and 3 phase)
- Import Active Power (Total and 3 phase)
- Export Active Power (Total and 3 phase)
- Import Reactive Power (Total and 3 phase)
- Export Reactive Power (Total and 3 phase)
- Apparent Power (Total and 3 phase)
- Inductive Power Factor (Total and 3 phase)
- Capacitive Power Factor (Total and 3 phase)
- Frequency

MEASUREMENTS (MEAS)	→OK ↵ X	Min-Max Values (MIN-MA)	→OK ↵ X	Minimum Values (MIN)	→OK ↵ X	MIN VLN (VLN)	↵OK ↵ X	AVERAGE (AVG)
						↓		
						MIN VLL (VLL)	↵OK ↵ X	AVERAGE (AVG)
						↓		
						MIN CURRENT (I)	↵OK ↵ X	TOTAL (TOTAL)
						↓		
						MIN IMPORT ACTIVE POWER (P)	↵OK ↵ X	TOTAL (TOTAL)
						↓		
						MIN EXPORT ACTIVE POWER (P)	↵OK ↵ X	TOTAL (TOTAL)
						↓		
						MIN IMPORT REACTIVE POWER (Q)	↵OK ↵ X	TOTAL (TOTAL)
						↓		
						MIN EXPORT REACTIVE POWER (Q)	↵OK ↵ X	TOTAL (TOTAL)
						↓		
				MIN APPARENT POWER (S)	↵OK ↵ X	TOTAL (TOTAL)		
				↓				
				MIN INDUCTIVE POWER FACTOR (PF)	↵OK ↵ X	TOTAL (TOTAL)		
				↓				
				MIN CAPASITIVE POWER FACTOR (PF)	↵OK ↵ X	TOTAL (TOTAL)		
				↓				
				MIN FREQUENCY (F)				
				↓				
				MAX VLN (VLN)	↵OK ↵ X	AVERAGE (AVG)		
				↓				
				MAX VLL (VLL)	↵OK ↵ X	AVERAGE (AVG)		
				↓				
MAX CURRENT (I)	↵OK ↵ X	TOTAL (TOTAL)						
↓								
MAX IMPORT ACTIVE POWER (P)	↵OK ↵ X	TOTAL (TOTAL)						
↓								
MAX EXPORT ACTIVE POWER (P)	↵OK ↵ X	TOTAL (TOTAL)						
↓								
MAX IMPORT REACTIVE POWER (Q)	↵OK ↵ X	TOTAL (TOTAL)						
↓								
MAX EXPORT REACTIVE POWER (Q)	↵OK ↵ X	TOTAL (TOTAL)						
↓								
MAX APPARENT POWER (S)	↵OK ↵ X	TOTAL (TOTAL)						
↓								
MAX INDUCTIVE POWER FACTOR (PF)	↵OK ↵ X	TOTAL (TOTAL)						
↓								
MAX CAPASITIVE POWER FACTOR (PF)	↵OK ↵ X	TOTAL (TOTAL)						
↓								
MAX FREQUENCY (F)								

3.1.6 Input Counter (IN CNT)

In devices with a Digital Input, the activation count of the relevant input and the time it remains active (its unit is hour) is shown under this menu.

To set the digital inputs as counter, see the “3.2.3 Digital Input Settings (DI1 & DI2)” menu.

When DI1 and DGND terminals are short-circuited for at least the set delay time, the “IN1 COUNT” increases by 1, and the active time is counted. The total active time unit is displayed in hours under the “IN1 HOUR” tab.

When DI2 and DGND terminals are short-circuited for at least the set delay time, the “IN2 NUMBER” increases by 1, and the active time is counted. The total active time unit is displayed in hours under the “IN2 HOUR” tab.

MEASUREMENTS (MEAS)	1 OK X	Input Counters (IN CNT)	1 OK X	Input 1 Count (I1 CNT)
				↓
				Input 1 Hour (IN1 HOUR)
				↓
				Input 2 Count (I2 CNT)
				↓
Input 2 Hour (IN2 HOUR)				

3.1.7 General Counters (GE CNT)

Under this menu, there are "On Hour Counter", "Run Hour Counter" and "Power Interruption Counter".

On Hour Counter: The total on-hour of the device is counted. Its unit is hour.

Run Hour Counter: The total run hour of the device is counted. Its unit is hour.

Power Interruption Counter: Power interruption of the device is counted. The corresponding counter increments by 1 with each power cut.

MEASUREMENTS (MEAS)	1 OK X	General Counters (GE CNT)	1 OK X	On Hour Counter (ON HOUR)
				↓
				Run Hour Counter (RUN HOUR)
				↓
Power Interruption Counter (POWER INT)				

! Only the "Run Hour Counter" can be reset by the user.

3.1.8 Voltage-Current Unbalance Values (UNBLNC)

The unbalance data of the voltage and current signals measured in the device are displayed. The calculation formula is as follows.

- $V_{avg} = (V12 + V23 + V31) / 3$
- $MaxDevV = \max [\text{abs} (V1 - V_{avg}), \text{abs} (V2 - V_{avg}), \text{abs} (V3 - V_{avg})]$
- $Unbalance = MaxDevV / V_{avg}$

MEASUREMENTS (MEAS)	1 OK X	Unbalance (UNBLNC)	1 OK X	Voltage Unbalance (VLTAGE)
				↓
				Current Unbalance (CURRNT)

! In current calculations, a similar process is performed by taking the average of the phase currents.

3.2 SETTINGS (SET)

Device configurations are made under this tab.

SETTINGS (SET)	General Communication Settings (COMSET)	↩ ↪ OK X
	↓	
	Serial Connection Settings (SERIAL)	↩ ↪ OK X
	↓	
	Ethernet Settings (ETHRNT)	↩ ↪ OK X
	↓	
	D01	↩ ↪ OK X
	↓	
	D02	↩ ↪ OK X
	↓	
	D11	↩ ↪ OK X
	↓	
	D12	↩ ↪ OK X
	↓	
	Network Settings (NETWRK)	↩ ↪ OK X
	↓	
	Demand Settings (DEMAND)	↩ ↪ OK X
	↓	
	Alarm Settings (ALARM)	↩ ↪ OK X
	↓	
Device Settings (DEVICE)	↩ ↪ OK X	
↓		
Security Settings (SECURE)	↩ ↪ OK X	
↓		
Clear (CLEAR)	↩ ↪ OK X	

The menu structure above may vary in different models.

3.2.1 Communication Settings

KLEA 5 and POWYS 6 series devices have RS485 (Modbus RTU) and optionally Ethernet (Modbus TCP) interfaces. Settings for these interfaces and protocols are defined under this tab.

SETTINGS (SET)	→ OK ↩ X	General Communication Settings (COMSET)	→ OK ↩ X	Slave ID (ID)	↩ ↪ OK X	1 .. 247
				↓		
				Communication Type (COMTYP)		Modbus RTU (RTU) / Modbus TCP (TCP)
				↓		
				Baudrate (BAUD)	↩ ↪ OK X	1200 / 2400 / 4800 / 9600 19200 / 38400 / 57600
				↓		
		Parity (PARITY)		↩ ↪ OK X	None / Odd / Even	
		↓				
		Stop Bit (STOP)		↩ ↪ OK X	1 / 2	
		↓				
		Data Type (DATATYP)		↩ ↪ OK X	BE (Big Endian) / LE (Little Endian) BE SW (Big Endian Byte Swap) LE SW (Little Endian Byte Swap)	
		↓				
		IP Address (IP)		↩ ↪ OK X		
		↓				
		Subnet Mask (SUBNET)		↩ ↪ OK X		
		↓				
		Gateway Address (GWYADR)		↩ ↪ OK X		
		↓				
Port (PORT)	↩ ↪ OK X					
↓						
Timeout (TIMOUT)	↩ ↪ OK X					

3.2.1.1 General Communication Settings (COMSET)

Under this menu, the slave ID and communication type of the device are selected.

In the communication type tab, the communication interface is selected.

- When Modbus RTU communication is selected, the device will answer the queries received via RS485 again via RS485.
- When Modbus TCP communication is selected, the device will answer the incoming queries over Ethernet, again over Ethernet.

The KLEA 516RE device has a gateway function. It can transfer the data of other serial devices connected to it via the RS485 line to the relevant systems by converting them to Modbus TCP. This eliminates the need for an external Modbus converter.



4 remote connections are supported on devices with Ethernet interface.

3.2.1.2 Serial Connection Settings (SERIAL)

Under this menu, the following communication parameters, which will be required for MODBUS RTU communication, are set.

- Baudrate (BAUD)
1200 – 57600 baudrates are supported.
- Parity (PARITY)
Odd parity, even parity and none parity options are supported.
- Stop Bit (STOP)
Stop bit 1 and Stop bit 2 options are supported.
- Veri Tipi (DTATYP)

It is the menu where the bit order of the data to be sent is selected. The following sorting types are supported.

- BE (Big Endian)
- LE (Little Endian)
- BE SW (Big Endian Byte Swap)
- LE SW (Little Endian Byte Swap)

3.2.1.3 Ethernet Settings (ETHRNT)

The parameter settings that the device will use for Internet access and Modbus TCP communication are made under this tab.

IP Address

The IP address in the local network is entered.

Default value: 92.168.34.70

Subnet Mask

Used to determine if two IP addresses are on the same network.

Default value 255.255.248.0

Gateway Address

It is used for communication between different networks.

Default value: 192.168.35.254

Port

The port to be communicated over Modbus is set.

Default value: 502

Timeout

It is the tab where the timeout setting is made.

Default value 1000 (unit is msec)

3.2.2 Digital Output Settings (D01 & D02)

There are optionally 2 digital outputs in the devices. Digital outputs are used to get pulses according to the counted energy value.

SETTINGS (SET)	→OK ↵ X	D01	→OK ↵ X	Source (SOURCE)	→OK ↵ X	T1 Total Import Active (I ACT) ↓ T1 Total Export Active (E ACT) ↓ T1 Total Import Reactive (I REA) ↓ T1 Total Export Reactive (E REA)
				Value (VALUE)	→OK ↵ X	1 .. 9
				Multiplier (MULT)	→OK ↵ X	1 x10 (M10) x100 (M100) x1000 (M1000) /1000 (D1000) /100 (D100) /10 (D10)
				Duration (DUR)	→OK ↵ X	30 .. 2500 msec
				↓		
				↵ X		
	→OK ↵ X	D02	→OK ↵ X	Source (SOURCE)	→OK ↵ X	T1 Total Import Active (I ACT) ↓ T1 Total Export Active (E ACT) ↓ T1 Total Import Reactive (I REA) ↓ T1 Total Export Reactive (E REA)
				Value (VALUE)	→OK ↵ X	1 .. 9
				Multiplier (MULT)	→OK ↵ X	1 x10 (M10) x100 (M100) x1000 (M1000) /1000 (D1000) /100 (D100) /10 (D10)
				Duration (DUR)	→OK ↵ X	30 .. 2500 msec
				↓		
				↵ X		

In the configuration of the digital output, the energy source to get pulses, the amount of energy to be counted to get pulses and the duration of the signal must be entered.

Source (SOURCE): The source of the energy to get pulses is selected. 4 different energy sources can be selected.

- Import Active Energy (I ACT)
- Export Active Energy (E ACT)
- Import Reactive Energy (I REA)
- Export Reactive Energy (E REA)

Value (VALUE) ve Multiplier (MULT): An integer from 1 to 9 must be entered for "Value". It is multiplied by the parameter selected from the "Multiplier" section and it is determined how much energy will be counted for a pulse.

Duration (DUR): The duration that the pulse will remain active is set.

For example, D01 configurations are as follows;

Source (SOURCE) ➔ Import Active Energy (I ACT)

Value (VALUE) ➔ 5

Multiplier (MULT) ➔ M10 (means multiply by 10)

Duration (DUR) ➔ 1000 (unit is msec.)

The device will give 1 pulse output for every 5x10 = 50Wh energy. The pulse will remain active for 1000 msec (1 second).

! These values are the total energy data of the 1st tariff. Energy units are Wh and VARh.

3.2.3 Digital Input Settings (DI1 & DI2)

Operating mode (SOURCE), delay time (DELAY), and detection edge (EDGE) settings of the inputs are made under this tab.

SETTINGS (SET)	→OK ↵ X	DI1	→OK ↵ X	Source (SOURCE)	→OK ↵ X	Input Counter (IN CNT)
						↓
						Tariff (TARIFF)
				Delay (DELAY)	→OK ↵ X	100 .. 2000 msec
				↓		
	Edge (EDGE)	→OK ↵ X	Rising Edge (RISE)			
			↓			
			Falling Edge (FALL)			
			↓			
			Rising and Falling Edge (BOTH)			

Digital Input Source (SOURCE): The operating mode configuration of the digital input is made under this tab. There are 2 different operating modes: 2nd tariff activation (TARIFF) and input counter (IN CNT).

If the source is set as tariff activation for both inputs;
When DI1 is active, the device will start counting to the 2nd tariff, and when DI2 is active, the device will start to count to the 3rd tariff.

! 2 different tariffs cannot be active with devices at the same time. If one tariff is active and the other tariff is desired to be activated, the device will only count on the 1st tariff.

If the source is set to input counter (IN CNT), it counts with each state changing depending on the detection edge.

- If rising edge detection (RISE) is chosen for the detection edge, the counter will increase by 1 on each activation of the dry contact that is connected to the digital input.
- If falling edge detection (FALL) is chosen for the detection edge, the counter will increase by 1 on each deactivation of the dry contact that is connected to the digital input.
- If rising and falling edges detection (BOTH) is chosen for the detection edge, the counter will increase by 1 on each activation and deactivation of the dry contact that is connected to the digital input.

Delay (DELAY): The input is enabled or disabled based on the detection delay time which is set to account for contact spikes or noise in the digital input.

Detection Edge (EDGE): Use this menu item to choose the position where the digital input is detected active or passive. This menu is available only for the digital input mode (IN CNT). 2nd tariff activation always uses rising edge detection.

! When digital inputs are set as input counter, tariff configuration is done using commands over communication.

! Digital input is based on the dry contact detection principle. Never apply signal to inputs. Otherwise, there is a risk of damaging the device.

3.2.4 Network Settings (NETWRK)

The network and basic settings of the device are made under this tab.

SETTINGS (SET)	→OK ↵ X	Network Settings (NETWRK)	←OK ↵ X	CT Primary (CT PRI)	5 .. 9999
				↓	
				CT Secondary (CT SEC)	1 / 5
				↓	
				VT Primary (VT PRI)	100 .. 999999
				↓	
				VT Secondary (VT SEC)	100 .. 500
				↓	
				System Frequency (SYSFRQ)	50 / 60
↓					
Connection Typw (CONTYP)	3P4W / 3P3W				
↓					
Transformer Option (TRA)	WITH / WITHOUT				

CT Primary Setting (CT PRI): This is the section where the primary value of the current transformers connected to the current inputs is entered. A value between 5 and 9999 can be entered.

CT Secondary Setting (CT SEC): Akım girişlerine bağlanan akım trafolarının sekonder değerinin girildiği bölümdür. 1 veya 5 girilmektedir.

The current values measured from the current inputs are multiplied by the ratio of the CT Primary and CT Secondary values and shown in the displays and Modbus addresses.

VT Primary Setting (VT PRI): This is the section where the primary value of the transformers connected to the voltage inputs is entered. A value between 100 and 9999 can be entered.

VT Secondary Setting (VT SEC): This is the section where the secondary value of the transformers connected to the voltage inputs is entered. A value between 100 and 500 can be entered.

The voltage values measured from the voltage inputs are multiplied by the ratio of the VT Primary and VT Secondary values and shown in the displays and Modbus addresses.

System Frequency (SYSFRQ): It is the section where the system frequency is selected. 50 and 60 Hz frequencies are supported on the devices.

Connection Type (CONTYP): The connection type to the device is selected under this tab. 3P3W and 3P4W connection options are supported on the devices.

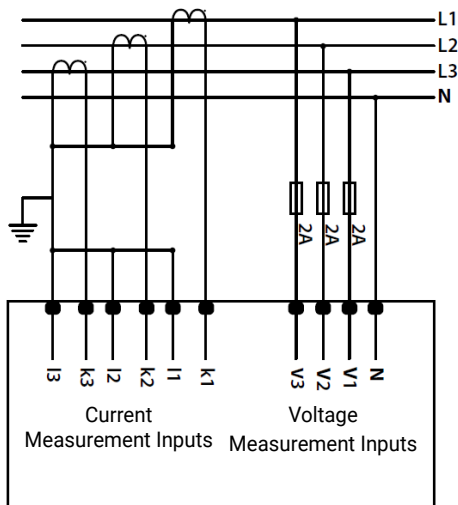

Figure 3 3P4W Connection

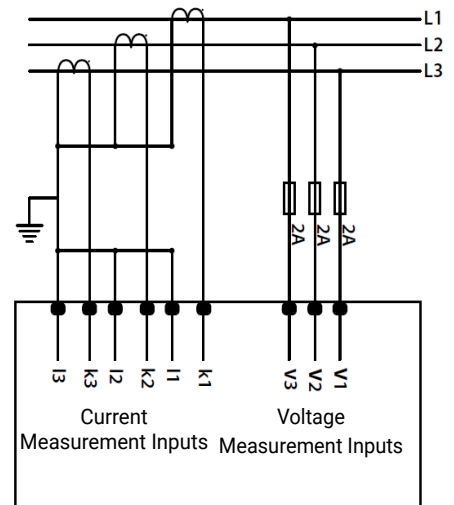

Figure 4 3P3W Connection

Transformer Option (TRA): The connection type to the device is selected under this tab. 3P3W and 3P4W connection options are supported on the devices.

For example, CT ratio, VT ratio, current and voltage values are as follows.

- CT ratio: 100
- Measured 1st phase current: 100A (1A without CT ratio)
- VT ratio: 1
- Measured 1st phase voltage: 230

When the transformer option is set to “ON”, the index increase after one hour for the 1st phase;
 $230 \times 100 = 23000$ (23 kWh)

When the transformer option is set to “OFF”, the index increase after one hour for the 1st phase;
 $230 \times 1 = 230$ Wh

! The Transformer Option is only for changing the increase in the index data, and the current and voltage values shown on the screen will be displayed with a multiplier independent of this parameter.

3.2.5 Demand Settings (DEMAND)

Under this tab, the demand calculation method and period are entered. The device has 3 different demand calculation methods: fixed, sliding, and rolling.

SETTINGS (SET)	→OK ↵ X	Demand Settings (DEMAND)	→OK ↵ X	Method (METHOD)	→OK ↵ X	Sliding (SLIDIN)
						↓
						Fixed (FIXED)
						↓
						Rolling (ROLLIN)
				Period (PERIOD)	→OK ↵ X	1..60
				↓		
				Sun Interval (SUBINT)	→OK ↵ X	1..60

Fixed Method: It is calculated by taking the average of the power values during the set demand period.

Sliding Method: Demand values are calculated in blocks of time determined according to the set time. Time blocks are the value in seconds of demand time intervals set in minutes. In other words, the demand measurements of a device with a demand time of 15 minutes are updated with time blocks of each 15 seconds. The device updates the demand value at the end of the time interval.

Rolling Method: Demand values are calculated in blocks of time determined according to the set time. Time blocks are the value in seconds of demand time intervals set in minutes. In other words, the demand measurements of a device with a demand time of 15 minutes are updated with time blocks of each 15 seconds. The device updates the demand value at the end of the time interval.

The default values are as follows.

- Method: Sliding
- Period: 15 mins.
- Sub-Interval: 1 min. (It is unimportant in demand calculation because its method is “Sliding”)

3.2.6 Alarm Settings (ALARM)

Alarm limits, hysteresis values, delay times, and relay assignment settings are made for the following parameters under this menu.

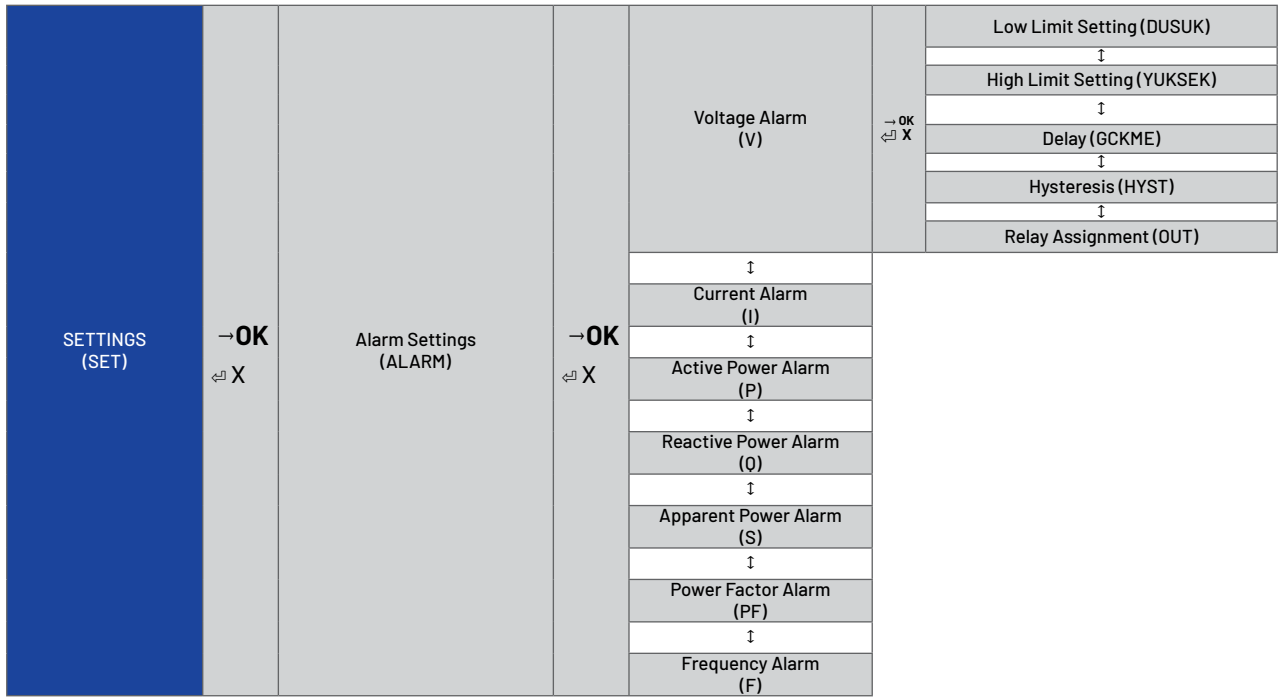

- **Voltage**

- **Low (LOW)**
Low voltage limit setting is made.
- **High (HIGH)**
High voltage limit setting is made.
- **Delay (DELAY)**
The delay time for the voltage alarm to be detected is set.
- **Hysteresis (HYST)**
Voltage alarm hysteresis setting is made.
- **Relay Assignment (Out)**
Relay assignment is made for the related alarm parameter in this tab for devices with relay output.

- **Current**
- **Frequency**
- **Active Power**
- **Reactive Power**
- **Apparent Power**
- **Power Factor**



When it is desired to set the alarm as off state for a parameter, the low and high values have to be entered as the same.

E.g.

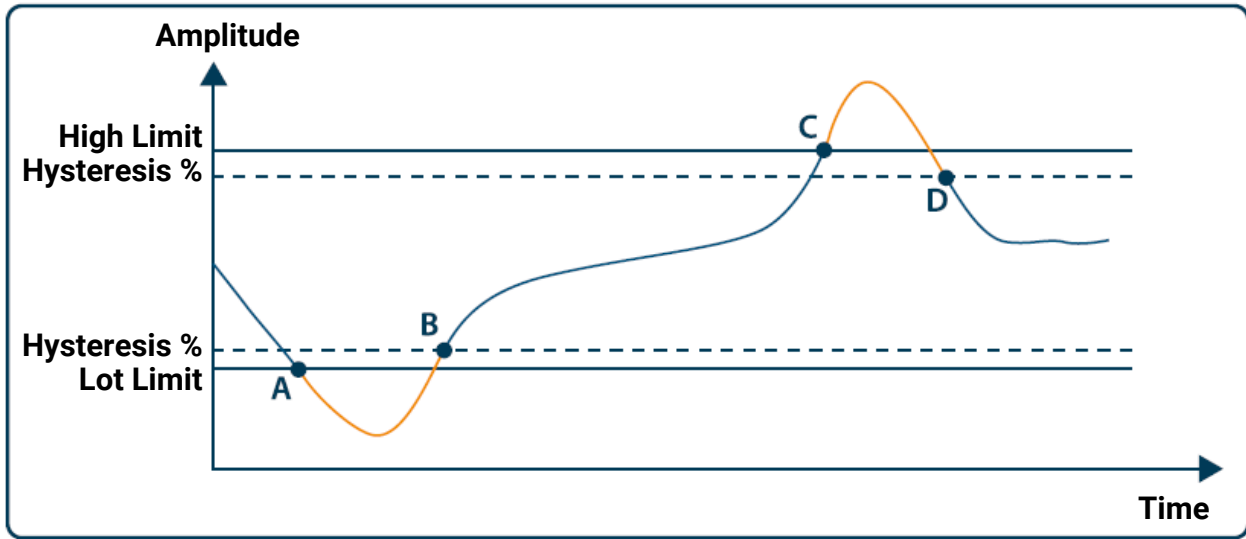

- Point A low limit alarm occurs.
- Point B, the alarm condition disappears.
- Point C high limit alarm occurs.
- Point D, the alarm condition disappears.

3.2.7 Device Settings (DEVICE)

Under this tab, the language of the device, backlight status, and menu settings are made.

SETTINGS (SET)	→OK ↵ X	Device Settings (DEVICE)	→OK ↵ X	Language (LANG DIL)	↵ OK ↵ X	Türkçe (TURKCE) English (ENGLISH)				
				Backlight (BCKLGH)	↵ OK ↵ X	Backlight State (STATE)	↵ OK ↵ X	Time Dependent (TIME)		
								Off (OFF)		
								On (ON)		
								Time (TIME)	↵ OK ↵ X	10..600
								Scroll (SCROLL)	↵ OK ↵ X	ON OFF
				Menü (MENÜ)	↵ OK ↵ X			Start Page (START)	↵ OK ↵ X	Instant Values (INSTAN) Energy Values (ENERGY)
								Scroll Period (PERIOD)	↵ OK ↵ X	1..60

The device supports 2 different language options, Turkish and English. The default language is English.

The backlight can be adjusted in 3 different options: continuously on (ON), continuously off (OFF), and time-dependent (TIMDEP). If it is selected time-dependent, how long it will remain active (TIME) should be selected.

In the menu setting, the start screen (START), the menu loop (SCROLL), and the time required to stay on each page (PERIOD) are set.

Two different start screens can be selected, instantaneous measurements and energy. When the scroll is activated, the values are displayed by waiting for the cycle time (PERIOD) among the selected start screen parameters.

3.2.8 Security Settings (SECURE)

Password protection activation configuration (ACTIVE) and password (PASS) can be adjusted under this tab.

SETTINGS (SET)	→OK ↵ X	Security Settings (SECURE)	→OK ↵ X	Activation (ACTIVE)	→OK ↵ X	OFF ON
				↓		
				Password (PASS)	→OK ↵ X	000000 .. 999999

3.2.9 Clear (CLEAR)

6 different parameters can be cleared under this menu.

SETTINGS (SET)	→OK ↵ X	Clear (CLEAR)	→OK ↵ X	Settings (SET)	→OK ↵ X	NO YES
				↓		
				Energy (ENERGY)	→OK ↵ X	NO YES
				↓		
				Demand (DEMAND)	→OK ↵ X	NO YES
				↓		
				Min & Max (MIN-MA)	→OK ↵ X	NO YES
				↓		
				Input Counter (IN CNT)	→OK ↵ X	NO YES
				↓		
				General Counter (GE CNT)	→OK ↵ X	NO YES

The parameter to be cleared should be set to "YES". When exiting the settings menu, selecting "YES" for the "SAVE" question will delete the settings.

! In order to save the settings made after the setting change, the "X" button must be pressed several times. The "NO" statement on the "SAVE" screen that appears on the screen should be changed to "YES" using the buttons. Afterward, the "OK" button should be pressed.

3.3 INFO (INFO)

Device information is shown under this tab.

INFO (INFO)	→OK ↵ X	Order Number (ORDER)
		↓
		Serial Number (SERIAL NO)
		↓
		Yazılım Versiyonu (FIRMWARE)
		↓
		Modbus Versiyonu (MDDBUS)
		↓
MAC Adresi (High) (MAC HI)		
↓		
MAC Adresi (Low) (MAC LO)		

3.4 LOGIN (LOGIN)

This is the section where the password is entered. When the password is entered successfully, "OK" appears on the screen.



KLEA 5 & POWYS 6

SECTION 4
RS485
COMMUNICATION

The devices have an optional RS485 interface. Devices communicate with Modbus RTU protocol over the RS485 communication interface. The following functions are supported.

- 03H fonksiyonu: This function reads the readable addresses in the Modbus table.
- 10H fonksiyonu: This function writes the writable addresses in the Modbus table.

Definitions:

R / W: Can read and write the value in this address.

RO: Can only read the value in this address.

WO: Can only write to this address.

float: 32-bit floating number.

Phase Values (3Ph)						
Item	Parameter	Type	W/R	Function	Description	Default
0	Average Phase Neutral Voltage	float	RO	03H	V	
2	Total Current	float	RO	03H	A	
4	Total Active Power	float	RO	03H	W	
6	Total Reactive Power	float	RO	03H	VAr	
8	Total Apparent Power	float	RO	03H	VA	
10	System Power Factor	float	RO	03H	-	
12	Frequency	float	RO	03H	Hz	
14	Neutral Current	float	RO	03H	A	
16	Phase - Phase Voltage V12	float	RO	03H	V	
18	Phase - Phase Voltage V23	float	RO	03H	V	
20	Phase - Phase Voltage V31	float	RO	03H	V	
22	Average Phase - Phase Voltage	float	RO	03H	V	
24	Voltage Sequence	int32t	RO	03H	-	

Phase Values (1Ph)						
Item	Parameter	Type	W/R	Function	Description	Default
100	Phase 1 Voltage	float	RO	03H	V	
102	Phase 2 Voltage	float	RO	03H	V	
104	Phase 3 Voltage	float	RO	03H	V	
106	Phase 1 Current	float	RO	03H	A	
108	Phase 2 Current	float	RO	03H	A	
110	Phase 3 Current	float	RO	03H	A	
112	Phase 1 Active Power	float	RO	03H	W	
114	Phase 2 Active Power	float	RO	03H	W	
116	Phase 3 Active Power	float	RO	03H	W	
118	Phase 1 Reactive Power	float	RO	03H	VAr	
120	Phase 2 Reactive Power	float	RO	03H	VAr	
122	Phase 3 Reactive Power	float	RO	03H	VAr	
124	Phase 1 Apparent Power	float	RO	03H	VA	
126	Phase 2 Apparent Power	float	RO	03H	VA	
128	Phase 3 Apparent Power	float	RO	03H	VA	
130	Phase 1 Power Factor	float	RO	03H	-	
132	Phase 2 Power Factor	float	RO	03H	-	
134	Phase 3 Power Factor	float	RO	03H	-	
136	Phase 1 Cos \emptyset	float	RO	03H	-	
138	Phase 2 Cos \emptyset	float	RO	03H	-	
140	Phase 3 Cos \emptyset	float	RO	03H	-	

THD Values						
Item	Parameter	Type	W/R	Function	Description	Default
500	Phase 1 THDV	float	RO	03H	%	
502	Phase 2 THDV	float	RO	03H	%	
504	Phase 3 THDV	float	RO	03H	%	
506	Phase 1 THDI	float	RO	03H	%	
508	Phase 2 THDI	float	RO	03H	%	
510	Phase 3 THDI	float	RO	03H	%	

Harmonic Values						
Item	Parameter	Type	W/R	Function	Description	Default
600	Voltage Harmonics 1 Phase 1	float	RO	03H	%	
602	Voltage Harmonics 3 Phase 1	float	RO	03H	%	
604	Voltage Harmonics 5 Phase 1	float	RO	03H	%	
606	Voltage Harmonics 7 Phase 1	float	RO	03H	%	
608	Voltage Harmonics 9 Phase 1	float	RO	03H	%	
610	Voltage Harmonics 11 Phase 1	float	RO	03H	%	
612	Voltage Harmonics 13 Phase 1	float	RO	03H	%	
614	Voltage Harmonics 15 Phase 1	float	RO	03H	%	
616	Voltage Harmonics 17 Phase 1	float	RO	03H	%	
618	Voltage Harmonics 19 Phase 1	float	RO	03H	%	
620	Voltage Harmonics 21 Phase 1	float	RO	03H	%	
622	Voltage Harmonics 23 Phase 1	float	RO	03H	%	
624	Voltage Harmonics 25 Phase 1	float	RO	03H	%	

Harmonic Values						
Item	Parameter	Type	W/R	Function	Description	Default
626	Voltage Harmonics 27 Phase 1	float	RO	03H	%	
628	Voltage Harmonics 29 Phase 1	float	RO	03H	%	
630	Voltage Harmonics 31 Phase 1	float	RO	03H	%	
632	Voltage Harmonics 1 Phase 2	float	RO	03H	%	
634	Voltage Harmonics 3 Phase 2	float	RO	03H	%	
636	Voltage Harmonics 5 Phase 2	float	RO	03H	%	
638	Voltage Harmonics 7 Phase 2	float	RO	03H	%	
640	Voltage Harmonics 9 Phase 2	float	RO	03H	%	
642	Voltage Harmonics 11 Phase 2	float	RO	03H	%	
644	Voltage Harmonics 13 Phase 2	float	RO	03H	%	
646	Voltage Harmonics 15 Phase 2	float	RO	03H	%	
648	Voltage Harmonics 17 Phase 2	float	RO	03H	%	
650	Voltage Harmonics 19 Phase 2	float	RO	03H	%	
652	Voltage Harmonics 21 Phase 2	float	RO	03H	%	
654	Voltage Harmonics 23 Phase 2	float	RO	03H	%	
656	Voltage Harmonics 25 Phase 2	float	RO	03H	%	
658	Voltage Harmonics 27 Phase 2	float	RO	03H	%	
660	Voltage Harmonics 29 Phase 2	float	RO	03H	%	
662	Voltage Harmonics 31 Phase 2	float	RO	03H	%	
664	Voltage Harmonics 1 Phase 3	float	RO	03H	%	
666	Voltage Harmonics 3 Phase 3	float	RO	03H	%	
668	Voltage Harmonics 5 Phase 3	float	RO	03H	%	
670	Voltage Harmonics 7 Phase 3	float	RO	03H	%	
672	Voltage Harmonics 9 Phase 3	float	RO	03H	%	
674	Voltage Harmonics 11 Phase 3	float	RO	03H	%	
676	Voltage Harmonics 13 Phase 3	float	RO	03H	%	
678	Voltage Harmonics 15 Phase 3	float	RO	03H	%	
680	Voltage Harmonics 17 Phase 3	float	RO	03H	%	
682	Voltage Harmonics 19 Phase 3	float	RO	03H	%	
684	Voltage Harmonics 21 Phase 3	float	RO	03H	%	
686	Voltage Harmonics 23 Phase 3	float	RO	03H	%	
688	Voltage Harmonics 25 Phase 3	float	RO	03H	%	
690	Voltage Harmonics 27 Phase 3	float	RO	03H	%	
692	Voltage Harmonics 29 Phase 3	float	RO	03H	%	
694	Voltage Harmonics 31 Phase 3	float	RO	03H	%	
696	Current Harmonics 1 Phase 1	float	RO	03H	%	
698	Current Harmonics 3 Phase 1	float	RO	03H	%	
700	Current Harmonics 5 Phase 1	float	RO	03H	%	
702	Current Harmonics 7 Phase 1	float	RO	03H	%	
704	Current Harmonics 9 Phase 1	float	RO	03H	%	
706	Current Harmonics 11 Phase 1	float	RO	03H	%	
708	Current Harmonics 13 Phase 1	float	RO	03H	%	
710	Current Harmonics 15 Phase 1	float	RO	03H	%	
712	Current Harmonics 17 Phase 1	float	RO	03H	%	
714	Current Harmonics 19 Phase 1	float	RO	03H	%	
716	Current Harmonics 21 Phase 1	float	RO	03H	%	
718	Current Harmonics 23 Phase 1	float	RO	03H	%	
720	Current Harmonics 25 Phase 1	float	RO	03H	%	
722	Current Harmonics 27 Phase 1	float	RO	03H	%	
724	Current Harmonics 29 Phase 1	float	RO	03H	%	

Harmonic Values						
Item	Parameter	Type	W/R	Function	Description	Default
726	Current Harmonics 31 Phase 1	float	RO	03H	%	
728	Current Harmonics 1 Phase 2	float	RO	03H	%	
730	Current Harmonics 3 Phase 2	float	RO	03H	%	
732	Current Harmonics 5 Phase 2	float	RO	03H	%	
734	Current Harmonics 7 Phase 2	float	RO	03H	%	
736	Current Harmonics 9 Phase 2	float	RO	03H	%	
738	Current Harmonics 11 Phase 2	float	RO	03H	%	
740	Current Harmonics 13 Phase 2	float	RO	03H	%	
742	Current Harmonics 15 Phase 2	float	RO	03H	%	
744	Current Harmonics 17 Phase 2	float	RO	03H	%	
746	Current Harmonics 19 Phase 2	float	RO	03H	%	
748	Current Harmonics 21 Phase 2	float	RO	03H	%	
750	Current Harmonics 23 Phase 2	float	RO	03H	%	
752	Current Harmonics 25 Phase 2	float	RO	03H	%	
754	Current Harmonics 27 Phase 2	float	RO	03H	%	
756	Current Harmonics 29 Phase 2	float	RO	03H	%	
758	Current Harmonics 31 Phase 2	float	RO	03H	%	
760	Current Harmonics 1 Phase 3	float	RO	03H	%	
762	Current Harmonics 3 Phase 3	float	RO	03H	%	
764	Current Harmonics 5 Phase 3	float	RO	03H	%	
766	Current Harmonics 7 Phase 3	float	RO	03H	%	
768	Current Harmonics 9 Phase 3	float	RO	03H	%	
770	Current Harmonics 11 Phase 3	float	RO	03H	%	
772	Current Harmonics 13 Phase 3	float	RO	03H	%	
774	Current Harmonics 15 Phase 3	float	RO	03H	%	
776	Current Harmonics 17 Phase 3	float	RO	03H	%	
778	Current Harmonics 19 Phase 3	float	RO	03H	%	
780	Current Harmonics 21 Phase 3	float	RO	03H	%	
782	Current Harmonics 23 Phase 3	float	RO	03H	%	
784	Current Harmonics 25 Phase 3	float	RO	03H	%	
786	Current Harmonics 27 Phase 3	float	RO	03H	%	
788	Current Harmonics 29 Phase 3	float	RO	03H	%	
790	Current Harmonics 31 Phase 3	float	RO	03H	%	

Energy Values						
Item	Parameter	Type	W/R	Function	Description	Default
1000	Total Import Active Energy	double	RO	03H	Wh	
1004	Total Phase 1 Import Active Energy	double	RO	03H	Wh	
1008	Total Phase 2 Import Active Energy	double	RO	03H	Wh	
1012	Total Phase 3 Import Active Energy	double	RO	03H	Wh	
1016	Total Export Active Energy	double	RO	03H	Wh	
1020	Total Phase 1 Export Active Energy	double	RO	03H	Wh	
1024	Total Phase 2 Export Active Energy	double	RO	03H	Wh	
1028	Total Phase 3 Export Active Energy	double	RO	03H	Wh	
1032	Total Import Reactive Energy	double	RO	03H	VArh	
1036	Total Phase 1 Import Reactive Energy	double	RO	03H	VArh	
1040	Total Phase 2 Import Reactive Energy	double	RO	03H	VArh	
1044	Total Phase 3 Import Reactive Energy	double	RO	03H	VArh	

Energy Values						
Item	Parameter	Type	W/R	Function	Description	Default
1048	Total Export Reactive Energy	double	RO	03H	VARh	
1052	Total Phase 1 Export Reactive Energy	double	RO	03H	VARh	
1056	Total Phase 2 Export Reactive Energy	double	RO	03H	VARh	
1060	Total Phase 3 Export Reactive Energy	double	RO	03H	VARh	
1064	Total T1 Import Active Energy	double	RO	03H	Wh	
1068	Phase 1 T1 Import Active Energy	double	RO	03H	Wh	
1072	Phase 2 T1 Import Active Energy	double	RO	03H	Wh	
1076	Phase 3 T1 Import Active Energy	double	RO	03H	Wh	
1080	Total T1 Export Active Energy	double	RO	03H	Wh	
1084	Phase 1 T1 Export Active Energy	double	RO	03H	Wh	
1088	Phase 2 T1 Export Active Energy	double	RO	03H	Wh	
1092	Phase 3 T1 Export Active Energy	double	RO	03H	Wh	
1096	Total T1 Import Reactive Energy	double	RO	03H	VARh	
1100	Phase 1 T1 Import Reactive Energy	double	RO	03H	VARh	
1104	Phase 2 T1 Import Reactive Energy	double	RO	03H	VARh	
1108	Phase 3 T1 Import Reactive Energy	double	RO	03H	VARh	
1112	Total T1 Export Reactive Energy	double	RO	03H	VARh	
1116	Phase 1 T1 Export Reactive Energy	double	RO	03H	VARh	
1120	Phase 2 T1 Export Reactive Energy	double	RO	03H	VARh	
1124	Phase 3 T1 Export Reactive Energy	double	RO	03H	VARh	
1128	Total T2 Import Active Energy	double	RO	03H	Wh	
1132	Phase 1 T2 Import Active Energy	double	RO	03H	Wh	
1136	Phase 2 T2 Import Active Energy	double	RO	03H	Wh	
1140	Phase 3 T2 Import Active Energy	double	RO	03H	Wh	
1144	Total T2 Export Active Energy	double	RO	03H	Wh	
1148	Phase 1 T2 Export Active Energy	double	RO	03H	Wh	
1152	Phase 2 T2 Export Active Energy	double	RO	03H	Wh	
1156	Phase 3 T2 Export Aktif Energy	double	RO	03H	Wh	
1160	Total T2 Import Reactive Energy	double	RO	03H	VARh	
1164	Phase 1 T2 Import Reactive Energy	double	RO	03H	VARh	
1168	Phase 2 T2 Import Reactive Energy	double	RO	03H	VARh	
1172	Phase 3 T2 Import Reactive Energy	double	RO	03H	VARh	
1176	Total T2 Export Reactive Energy	double	RO	03H	VARh	
1180	Phase 1 T2 Export Reactive Energy	double	RO	03H	VARh	
1184	Phase 2 T2 Export Reactive Energy	double	RO	03H	VARh	
1188	Phase 3 T2 Export Reactive Energy	double	RO	03H	VARh	
1192	Total T3 Import Active Energy	double	RO	03H	Wh	
1196	Phase 1 T3 Import Active Energy	double	RO	03H	Wh	
1200	Phase 2 T3 Import Active Energy	double	RO	03H	Wh	
1204	Phase 3 T3 Import Active Energy	double	RO	03H	Wh	
1208	Total T3 Export Active Energy	double	RO	03H	Wh	
1212	Phase 1 T3 Export Active Energy	double	RO	03H	Wh	
1216	Phase 2 T3 Export Active Energy	double	RO	03H	Wh	
1220	Phase 3 T3 Export Active Energy	double	RO	03H	Wh	
1224	Total T3 Import Reactive Energy	double	RO	03H	VARh	
1228	Phase 1 T3 Import Reactive Energy	double	RO	03H	VARh	

Energy Values						
Item	Parameter	Type	W/R	Function	Description	Default
1232	Phase 2 T3 Import Reactive Energy	double	RO	03H	VArh	
1236	Phase 3 T3 Import Reactive Energy	double	RO	03H	VArh	
1240	Total T3 Export Reactive Energy	double	RO	03H	VArh	
1244	Phase 1 T3 Export Reactive Energy	double	RO	03H	VArh	
1248	Phase 2 T3 Export Reactive Energy	double	RO	03H	VArh	
1252	Phase 3 T3 Export Reactive Energy	double	RO	03H	VArh	

Demand Values						
Item	Parameter	Type	W/R	Function	Description	Default
3000	PD* Phase 1 Current	float	RO	03H	A	
3002	PD* Phase 2 Current	float	RO	03H	A	
3004	PD* Phase 3 Current	float	RO	03H	A	
3006	PD* Total Current	float	RO	03H	-	
3008	PD* Total Import Active Power	float	RO	03H	W	
3010	PD* Total Export Active Power	float	RO	03H	W	
3012	PD* Total Import Reactive Power	float	RO	03H	VAr	
3014	PD* Total Export Reactive Power	float	RO	03H	VAr	
3016	PD* Total Apparent Power	float	RO	03H	VA	
3018	MD** Phase 1 Current	float	RO	03H	A	
3020	MD** Phase 2 Current	float	RO	03H	A	
3022	MD** Phase 3 Current	float	RO	03H	A	
3024	MD** Total Current	float	RO	03H	-	
3026	MD** Total Import Active Power	float	RO	03H	W	
3028	MD** Total Export Active Power	float	RO	03H	W	
3030	MD** Total Import Reactive Power	float	RO	03H	VAr	
3032	MD** Total Export Reactive Power	float	RO	03H	VAr	
3034	MD** Total Apparent Power	float	RO	03H	VA	

*PD: Demand data measured at the end of the previous demand period.

**MD: It is the maximum of the demand data measured in the device.

Min/Max Values						
Item	Parameter	Type	W/R	Function	Description	Default
4000	Minimum Phase 1 Voltage	float	RO	03H	V	
4002	Minimum Phase 2 Voltage	float	RO	03H	V	
4004	Minimum Phase 3 Voltage	float	RO	03H	V	
4006	Minimum Phase 1-2 Voltage	float	RO	03H	V	
4008	Minimum Phase 2-3 Voltage	float	RO	03H	V	
4010	Minimum Phase 3-1 Voltage	float	RO	03H	V	
4012	Minimum Phase 1 Current	float	RO	03H	A	
4014	Minimum Phase 2 Current	float	RO	03H	A	
4016	Minimum Phase 3 Current	float	RO	03H	A	
4018	Minimum Phase 1 Import Active Power	float	RO	03H	W	
4020	Minimum Phase 2 Import Active Power	float	RO	03H	W	
4022	Minimum Phase 3 Import Active Power	float	RO	03H	W	
4024	Minimum Phase 1 Export Active Power	float	RO	03H	W	
4026	Minimum Phase 2 Export Active Power	float	RO	03H	W	

Min/Max Values						
Item	Parameter	Type	W/R	Function	Description	Default
4028	Minimum Phase 3 Export Active Power	float	RO	03H	W	
4030	Minimum Phase 1 Import Reactive Power	float	RO	03H	VAr	
4032	Minimum Phase 2 Import Reactive Power	float	RO	03H	VAr	
4034	Minimum Phase 3 Import Reactive Power	float	RO	03H	VAr	
4036	Minimum Phase 1 Export Reactive Power	float	RO	03H	VAr	
4038	Minimum Phase 2 Export Reactive Power	float	RO	03H	VAr	
4040	Minimum Phase 3 Export Reactive Power	float	RO	03H	VAr	
4042	Minimum Phase 1 Apparent Power	float	RO	03H	VA	
4044	Minimum Phase 2 Apparent Power	float	RO	03H	VA	
4046	Minimum Phase 3 Apparent Power	float	RO	03H	VA	
4048	Minimum Phase 1 Inductive Power Factor	float	RO	03H	-	
4050	Minimum Phase 2 Inductive Power Factor	float	RO	03H	-	
4052	Minimum Phase 3 Inductive Power Factor	float	RO	03H	-	
4054	Minimum Phase 1 Capacitive Power Factor	float	RO	03H	-	
4056	Minimum Phase 2 Capacitive Power Factor	float	RO	03H	-	
4058	Minimum Phase 3 Capacitive Power Factor	float	RO	03H	-	
4060	Minimum Average Phase - Neutral Voltage	float	RO	03H	V	
4062	Minimum Average Phase - Neutral Voltage	float	RO	03H	V	
4064	Minimum Total Current	float	RO	03H	A	
4066	Minimum Total Import Active Power	float	RO	03H	W	
4068	Minimum Total Export Active Power	float	RO	03H	W	
4070	Minimum Total Import Reactive Power	float	RO	03H	VAr	
4072	Minimum Total Export Reactive Power	float	RO	03H	VAr	
4074	Minimum Total Apparent Power	float	RO	03H	VA	
4076	Minimum Total Inductive Power Factor	float	RO	03H	-	
4078	Minimum Total Capacitive Power Factor	float	RO	03H	-	
4080	Minimum Frequency	float	RO	03H	Hz	
4082	Maximum Phase 1 Voltage	float	RO	03H	V	
4084	Maximum Phase 2 Voltage	float	RO	03H	V	
4086	Maximum Phase 3 Voltage	float	RO	03H	V	
4088	Maximum Phase 1-2 Voltage	float	RO	03H	V	
4090	Maximum Phase 2-3 Voltage	float	RO	03H	V	
4092	Maximum Phase 3-1 Voltage	float	RO	03H	V	
4094	Maximum Phase 1 Current	float	RO	03H	A	
4096	Maximum Phase 2 Current	float	RO	03H	A	
4098	Maximum Phase 3 Current	float	RO	03H	A	
4100	Maximum Phase 1 Import Active Power	float	RO	03H	W	
4102	Maximum Phase 2 Import Active Power	float	RO	03H	W	
4104	Maximum Phase 3 Import Active Power	float	RO	03H	W	
4106	Maximum Phase 1 Export Active Power	float	RO	03H	W	
4108	Maximum Phase 2 Export Active Power	float	RO	03H	W	
4110	Maximum Phase 3 Export Active Power	float	RO	03H	W	
4112	Maximum Phase 1 Import Reactive Power	float	RO	03H	VAr	
4114	Maximum Phase 2 Import Reactive Power	float	RO	03H	VAr	
4116	Maximum Phase 3 Import Reactive Power	float	RO	03H	VAr	
4118	Maximum Phase 1 Export Reactive Power	float	RO	03H	VAr	

Min/Max Values						
Item	Parameter	Type	W/R	Function	Description	Default
4120	Maximum Phase 2 Export Reactive Power	float	RO	03H	VAr	
4122	Maximum Phase 3 Export Reactive Power	float	RO	03H	VAr	
4124	Maximum Phase 1 Apparent Power	float	RO	03H	VA	
4126	Maximum Phase 2 Apparent Power	float	RO	03H	VA	
4128	Maximum Phase 3 Apparent Power	float	RO	03H	VA	
4130	Maximum Phase 1 Inductive Power Factor	float	RO	03H	-	
4132	Maximum Phase 2 Inductive Power Factor	float	RO	03H	-	
4134	Maximum Phase 3 Inductive Power Factor	float	RO	03H	-	
4136	Maximum Phase 1 Capacitive Power Factor	float	RO	03H	-	
4138	Maximum Phase 2 Capacitive Power Factor	float	RO	03H	-	
4140	Maximum Phase 3 Capacitive Power Factor	float	RO	03H	-	
4142	Maximum Phase - Neutral Voltage	float	RO	03H	V	
4144	Maximum Phase - Phase Voltage	float	RO	03H	V	
4146	Maximum Total Current	float	RO	03H	A	
4148	Maximum Total Import Active Power	float	RO	03H	W	
4150	Maximum Total Export Active Power	float	RO	03H	W	
4152	Maximum Total Import Reactive Power	float	RO	03H	VAr	
4154	Maximum Total Export Reactive Power	float	RO	03H	VAr	
4156	Maximum Total Apparent Power	float	RO	03H	VA	
4158	Maximum Total Inductive Power Factor	float	RO	03H	-	
4160	Maximum Total Capacitive Power Factor	float	RO	03H	-	
4162	Maximum Frequency	float	RO	03H	Hz	

Digital Input Counter						
Item	Parameter	Type	W/R	Function	Description	Default
5000	Digital Input 1 Counter	uint32_t	RO	03H	-	
5002	Digital Input 1 Hour	uint32_t	RO	03H	hour	
5004	Digital Input 2 Counter	uint32_t	RO	03H	-	
5006	Digital Input 2 Hour	uint32_t	RO	03H	hour	

General Counters						
Item	Parameter	Type	W/R	Function	Description	Default
6000	On Hour Counter	uint32_t	RO	03H	hour	
6002	Run Hour Counter	uint32_t	RO	03H	hour	
6004	Power Interruption Counter	uint32_t	RO	03H	-	

Unbalance Values						
Item	Parameter	Type	W/R	Function	Description	Default
7000	Voltage Unbalance	float	RO	03H	%	
7002	Current Unbalance	float	RO	03H	%	

4 Quadrant Reactive Energy Values						
Item	Parameter	Type	W/R	Function	Description	Default
8000	Total Q1 Reactive Energy	double	RO	03H	VArh	
8004	Total Phase 1 Q1 Reactive Energy	double	RO	03H	VArh	
8008	Total Phase 2 Q1 Reactive Energy	double	RO	03H	VArh	
8012	Total Phase 3 Q1 Reactive Energy	double	RO	03H	VArh	
8016	Total Q2 Reactive Energy	double	RO	03H	VArh	
8020	Total Phase 1 Q2 Reactive Energy	double	RO	03H	VArh	
8024	Total Phase 2 Q2 Reactive Energy	double	RO	03H	VArh	
8028	Total Phase 3 Q2 Reactive Energy	double	RO	03H	VArh	
8032	Total Q3 Reactive Energy	double	RO	03H	VArh	
8036	Total Phase 1 Q3 Reactive Energy	double	RO	03H	VArh	
8040	Total Phase 2 Q3 Reactive Energy	double	RO	03H	VArh	
8044	Total Phase 3 Q3 Reactive Energy	double	RO	03H	VArh	
8048	Total Q4 Reactive Energy	double	RO	03H	VArh	
8052	Total Phase 1 Q4 Reactive Energy	double	RO	03H	VArh	
8056	Total Phase 2 Q4 Reactive Energy	double	RO	03H	VArh	
8060	Total Phase 3 Q4 Reactive Energy	double	RO	03H	VArh	
8064	T1 Q1 Reactive Energy	double	RO	03H	VArh	
8068	T1 Phase 1 Q1 Reactive Energy	double	RO	03H	VArh	
8072	T1 Phase 2 Q1 Reactive Energy	double	RO	03H	VArh	
8076	T1 Phase 3 Q1 Reactive Energy	double	RO	03H	VArh	
8080	T1 Q2 Reactive Energy	double	RO	03H	VArh	
8084	T1 Phase 1 Q2 Reactive Energy	double	RO	03H	VArh	
8088	T1 Phase 2 Q2 Reactive Energy	double	RO	03H	VArh	
8092	T1 Phase 3 Q2 Reactive Energy	double	RO	03H	VArh	
8096	T1 Q3 Reactive Energy	double	RO	03H	VArh	
8100	T1 Phase 1 Q3 Reactive Energy	double	RO	03H	VArh	
8104	T1 Phase 2 Q3 Reactive Energy	double	RO	03H	VArh	
8108	T1 Phase 3 Q3 Reactive Energy	double	RO	03H	VArh	
8112	T1 Q4 Reactive Energy	double	RO	03H	VArh	
8116	T1 Phase 1 Q4 Reactive Energy	double	RO	03H	VArh	
8120	T1 Phase 2 Q4 Reactive Energy	double	RO	03H	VArh	
8124	T1 Phase 3 Q4 Reactive Energy	double	RO	03H	VArh	
8128	T2 Q1 Reactive Energy	double	RO	03H	VArh	
8132	T2 Phase 1 Q1 Reactive Energy	double	RO	03H	VArh	
8136	T2 Phase 2 Q1 Reactive Energy	double	RO	03H	VArh	
8140	T2 Phase 3 Q1 Reactive Energy	double	RO	03H	VArh	
8144	T2 Q2 Reactive Energy	double	RO	03H	VArh	
8148	T2 Phase 1 Q2 Reactive Energy	double	RO	03H	VArh	
8152	T2 Phase 2 Q2 Reactive Energy	double	RO	03H	VArh	
8156	T2 Phase 3 Q2 Reactive Energy	double	RO	03H	VArh	
8160	T2 Q3 Reactive Energy	double	RO	03H	VArh	
8164	T2 Phase 1 Q3 Reactive Energy	double	RO	03H	VArh	
8168	T2 Phase 2 Q3 Reactive Energy	double	RO	03H	VArh	
8172	T2 Phase 3 Q3 Reactive Energy	double	RO	03H	VArh	
8176	T2 Q4 Reactive Energy	double	RO	03H	VArh	
8180	T2 Phase 1 Q4 Reactive Energy	double	RO	03H	VArh	

4 Quadrant Reactive Energy Values

Item	Parameter	Type	W/R	Function	Description	Default
8184	T2 Phase 2 Q4 Reactive Energy	double	RO	03H	VArh	
8188	T2 Phase 3 Q4 Reactive Energy	double	RO	03H	VArh	
8192	T3 Q1 Reactive Energy	double	RO	03H	VArh	
8196	T3 Phase 1 Q1 Reactive Energy	double	RO	03H	VArh	
8200	T3 Phase 2 Q1 Reactive Energy	double	RO	03H	VArh	
8204	T3 Phase 3 Q1 Reactive Energy	double	RO	03H	VArh	
8208	T3 Q2 Reactive Energy	double	RO	03H	VArh	
8212	T3 Phase 1 Q2 Reactive Energy	double	RO	03H	VArh	
8216	T3 Phase 2 Q2 Reactive Energy	double	RO	03H	VArh	
8220	T3 Phase 3 Q2 Reactive Energy	double	RO	03H	VArh	
8224	T3 Q3 Reactive Energy	double	RO	03H	VArh	
8228	T3 Phase 1 Q3 Reactive Energy	double	RO	03H	VArh	
8232	T3 Phase 2 Q3 Reaktif Energy	double	RO	03H	VArh	
8236	T3 Phase 3 Q3 Reactive Energy	double	RO	03H	VArh	
8240	T3 Q4 Reactive Energy	double	RO	03H	VArh	
8244	T3 Phase 1 Q4 Reactive Energy	double	RO	03H	VArh	
8248	T3 Phase 2 Q4 Reactive Energy	double	RO	03H	VArh	
8252	T3 Phase 3 Q4 Reactive Energy	double	RO	03H	VArh	

Configuration Activation

Item	Parameter	Type	W/R	Function	Description	Default
15000	Device Password	uint32_t	W	10H	1 - 999999	



In order to be able to configure via communication, the device password must be entered first. Then, other parameters can be configured.

Serial Communication Configuration

Item	Parameter	Type	W/R	Function	Description	Default
10000	Baudrate	uint32_t	R/W	03H/10H	0 - 1200 1 - 2400 2 - 4800 3 - 9600 4 - 19200 5 - 38400 6 - 57600	5
10002	Parity	uint32_t	R/W	03H/10H	0 - None Parity 1 - Odd 2 - Even	0
10004	Stop Bit	uint32_t	R/W	03H/10H	0 - STOP 1 1 - STOP 2	0
10006	Data Type	uint32_t	R/W	03H/10H	0 - BE 1 - LE 2 - BE SWAP 3 - LE SWAP	0

Digital Output 1 Configuration						
Item	Parameter	Type	W/R	Function	Description	Default
10100	Output 1 Source	uint32_t	R/W	03H/10H	0 - Imp. Active Energy 1 - Exp. Active Energy 2 - Imp. Reactive Energy 3 - Exp. Reactive Energy	0
10102	Output 1 Value	uint32_t	R/W	03H/10H	1-9(Wh/VArh)	1
10104	Output 1 Multiplier	uint32_t	R/W	03H/10H	0 - x 0,001 (B1000) 1 - x 0,01 (B100) 2 - x 0,1 (B10) 3 - x 1 4 - x 10 (C10) 5 - x 100 (C100) 6 - x 1000 (C1000)	3
10106	Output 1 Duration	uint32_t	R/W	03H/10H	30-2500 (msec)	500

Digital Output 2 Configuration						
Item	Parameter	Type	W/R	Function	Description	Default
10200	Output 2 Source	uint32_t	R/W	03H/10H	0 - Imp. Active Energy 1 - Exp. Active Energy 2 - Imp. Reactive Energy 3 - Exp. Reactive Energy	2
10202	Output 2 Value	uint32_t	R/W	03H/10H	1-9(Wh/VArh)	1
10204	Output 2 Multiplier	uint32_t	R/W	03H/10H	0 - x 0,001 (B1000) 1 - x 0,01 (B100) 2 - x 0,1 (B10) 3 - x 1 4 - x 10 (C10) 5 - x 100 (C100) 6 - x 1000 (C1000)	3
10206	Output 2 Duration	uint32_t	R/W	03H/10H	30-2500 (msec)	500

Digital Input Configuration						
Item	Parameter	Type	W/R	Function	Description	Default
10300	Input 1 Source	uint32_t	R/W	03H/10H	0 - Input Counter 1 - Tariff	0
10302	Input 1 Delay	uint32_t	R/W	03H/10H	100-2000 (msec)	200
10304	Input 1 Edge	uint32_t	R/W	03H/10H	0 - Rising 1 - Falling 2 - Both	0
10306	Input 2 Source	uint32_t	R/W	03H/10H	0 - Input Counter 1 - Tariff	0
10308	Input 2 Delay	uint32_t	R/W	03H/10H	100-2000 (msec)	200
10310	Input 2 Edge	uint32_t	R/W	03H/10H	0 - Rising 1 - Falling 2 - Both	2

Network Configuration						
Item	Parameter	Type	W/R	Function	Description	Default
10400	CT Primary	float	R/W	03H/10H	5-9999(A)	5
10402	CT Secondary	uint32_t	R/W	03H/10H	0 - CT / 5 1 - CT / 1	0
10404	VT Primary	float	R/W	03H/10H	100-1000000(V)	230
10406	VT Secondary	float	R/W	03H/10H	100-500(V)	230
10408	System Frequency	uint32_t	R/W	03H/10H	0 - 50Hz 1 - 60Hz	0
10410	Connection Type	uint32_t	R/W	03H/10H	0 - 3P4W 1 - 3P3W	0
10412	Transformer Option	uint32_t	R/W	03H/10H	0 - Off 1 - On	1

Demand Configuration						
Item	Parameter	Type	W/R	Function	Description	Default
10500	Demand Method	uint32_t	R/W	03H/10H	0 - Fixed 1 - Sliding 2 - Rolling	1
10502	Demand Period	uint32_t	R/W	03H/10H	1-60 (Minute)	15
10504	Sub-Interval	uint32_t	R/W	03H/10H	1-60 (Minute)	1

Voltage Alarm Configuration						
Item	Parameter	Type	W/R	Function	Description	Default
10700	Voltage Low Limit	float	R/W	03H/10H	0-500 (V)	0
10702	Voltage High Limit	float	R/W	03H/10H	0-500 (V)	0
10704	Voltage Alarm Delay	uint32_t	R/W	03H/10H	1-600(sec)	5
10706	Voltage Alarm Hysteresis	float	R/W	03H/10H	0-20(%)	5
10708	Voltage Alarm Output	uint32_t	R/W	03H/10H	0 - Off 1 - R1 2 - R2	0

Current Alarm Configuration						
Item	Parameter	Type	W/R	Function	Description	Default
10710	Current Low Limit	float	R/W	03H/10H	0-6 (A)	0
10712	Current High Limit	float	R/W	03H/10H	0-6 (A)	0
10714	Current Alarm Delay	uint32_t	R/W	03H/10H	1-600(sec)	5
10716	Current Alarm Hysteresis	float	R/W	03H/10H	0-20(%)	5
10718	Current Alarm Output	uint32_t	R/W	03H/10H	0 - Off 1 - R1 2 - R2	0

Active Power Alarm Configuration						
Item	Parameter	Type	W/R	Function	Description	Default
10720	Active Power Low Limit	float	R/W	03H/10H	0-3000 (W)	0
10722	Active Power High Limit	float	R/W	03H/10H	0-3000 (W)	0
10724	Active Power Alarm Delay	uint32_t	R/W	03H/10H	1-600 (sec)	5
10726	Active Power Alarm Hysteresis	float	R/W	03H/10H	0-20(%)	5
10728	Active Power Alarm Output	uint32_t	R/W	03H/10H	0 - Off 1 - R1 2 - R2	0

Reactive Power Alarm Configuration						
Item	Parameter	Type	W/R	Function	Description	Default
10730	Reactive Power Low Limit	float	R/W	03H/10H	0-3000 (VAr)	0
10732	Reactive Power High Limit	float	R/W	03H/10H	0-3000 (VAr)	0
10734	Reactive Power Alarm Delay	uint32_t	R/W	03H/10H	1-600 (sec)	5
10736	Reactive Power Alarm Hysteresis	float	R/W	03H/10H	0-20(%)	5
10738	Reactive Power Alarm Output	uint32_t	R/W	03H/10H	0 - Off 1 - R1 2 - R2	0

Apparent Power Alarm Configuration						
Item	Parameter	Type	W/R	Function	Description	Default
10740	Apparent Power Low Limit	float	R/W	03H/10H	0-3000 (VA)	0
10742	Apparent Power High Limit	float	R/W	03H/10H	0-3000 (VA)	0
10744	Apparent Power Alarm Delay	uint32_t	R/W	03H/10H	1-600 (sn)	5
10746	Apparent Power Alarm Hysteresis	float	R/W	03H/10H	0-20(%)	5
10748	Apparent Power Alarm Output	uint32_t	R/W	03H/10H	0 - Kapalı 1 - R1 2 - R2	0

Power Factor Alarm Configuration						
Item	Parameter	Type	W/R	Function	Description	Default
10750	Power Factor Low Limit	float	R/W	03H/10H	0-1	0
10752	Power Factor High Limit	float	R/W	03H/10H	0-1	0
10754	Power Factor Alarm Delay	uint32_t	R/W	03H/10H	1-600 (sec)	5
10756	Power Factor Alarm Hysteresis	float	R/W	03H/10H	0-20(%)	5
10758	Power Factor Alarm Output	uint32_t	R/W	03H/10H	0 - Off 1 - R1 2 - R2	0

Frequency Alarm Configuration

Item	Parameter	Type	W/R	Function	Description	Default
10760	Frequency Low Limit	float	R/W	03H/10H	45-65 (Hz)	0
10762	Frequency High Limit	float	R/W	03H/10H	45-65 (Hz)	0
10764	Frequency Alarm Delay	uint32_t	R/W	03H/10H	1-600 (sec)	5
10766	Frequency Alarm Hysteresis	float	R/W	03H/10H	0-20(%)	5
10768	Frequency Alarm Output	uint32_t	R/W	03H/10H	0 - Off 1 - R1 2 - R2	0

General Communication Configuration

Item	Parameter	Type	W/R	Function	Description	Default
10800	Slave ID	uint32_t	R/W	03H/10H	1-247	1
10802	Com. Type	uint32_T	R/W	03H/10H	0: RTU 1: TCP	0

Ethernet Configuration

Item	Parameter	Type	W/R	Function	Description	Default
11000	IP Adresi	uint32_t	R/W	03H/10H	0 - 4294967295	3232244294
11002	Alt Ağ Maskesi	uint32_t	R/W	03H/10H	0 - 4294967295	4294965248
11004	Gateway Adresi	uint32_t	R/W	03H/10H	0 - 4294967295	3232244734
11006	Port	uint32_t	R/W	03H/10H	0 - 65535	502
11008	Timeout	uint32_t	R/W	03H/10H	500 - 50000 msec	1000

! IP Address, Subnet Mask and Gateway Address parameters are written and read as 32 bits. For example; The following steps should be followed when the default IP Address "192.168.34.70" is written to the device. The value "192.168.34.70" is divided into 4 parts as 8 bits. The value 192 is allocated as 0xC0, value 168 as 0xA8, value 34 as 0x22, value 70 as 0x46. The decimal equivalent of the 32-bit 0xC0A82246 number obtained from these values, the number 3232244294, should be written to the relevant register.

Device Flags						
Item	Parameter	Type	W/R	Function	Description	Default
45000	Error Flags	uint32_t	R	10H	0x00000001 - Pulse 1 Error 0x00000002 - Pulse 2 Error 0x00000004 - Rotation Error 0x00000008 - Current Error	
45100	Alarm Flags	uint32_t	R	10H	0x00000001 - V Min Alarm 0x00000002 - I Min Alarm 0x00000004 - P Min Alarm 0x00000008 - Q Min Alarm 0x00000010 - S Min Alarm 0x00000020 - PF Min Alarm 0x00000040 - F Min Alarm 0x00010000 - V Max Alarm 0x00020000 - I Max Alarm 0x00040000 - P Max Alarm 0x00080000 - Q Max Alarm 0x00100000 - S Max Alarm 0x00200000 - PF Max Alarm 0x00400000 - F Max Alarm	
45200	Digital Input Flags	uint32_t	R	10H	0x00000001 - Input 1 0x00000002 - Input 2	

Command List						
Item	Parameter	Type	W/R	Function	Description	Default
20000	General Commands	uint16_t	W	06H	1000- Save Settings 1100- Return to Default 1200- Restart 1300- Clear Demand Data 1400- Clear Min/Max Data 1500- Clear Energy Data 1600- Clear Input Counter Data 1700- Activate 1st Tariff 1800- Activate 1st Tariff 1900- Activate 3rd Tariff 2000- Clear Run Hour Counter	

KLEA 5 & POWYS 6

SECTION 5

**FACTORY DEFAULT
SETTINGS**

Network Settings			
Parameter	Factory Default	Unit	Setting Range / Values
CT Primary	5	-	5-9999
CT Secondary	5	-	1/5
VT Primary	230	-	100-999999
VT Secondary	230	-	100-500
System Frequency	50	Hz	50/60
Connection Type	3P4W	-	3P4W / 3P3W
Transformer Option	Var	-	On / Off

Communication Settings			
Parameter	Factory Default	Unit	Setting Range / Values
Slave ID	1	-	1-247
Baudrate	38400	-	1200 / 4800 / 9600 / 19200 / 38400 / 57600
Parity	None	-	None / Odd / Even
Stop Bit	1	-	1-2
Data Type	BE	-	BE / LE / BE SW / LE SW
IP Address	192.168.34.70	-	
Port	502	-	

Alarm Settings			
Parameter	Factory Default	Unit	Setting Range / Values
Voltage (V)			
Low Limit	0	V	0-500
High Limit	0	V	0-500
Delay	5	sec	1-600
Hysteresis	5	%	5-20
Relay Assignment	Off	-	Off / R1 / R2
Current (I)			
Low Limit	0.00	A	0.00 - 6.00
High Limit	0.00	A	0.00 - 6.00
Delay	5	sec	1-600
Hysteresis	5	%	5-20
Relay Assignment	Off	-	Off / R1 / R2
Frequency (F)			
Low Limit	0	Hz	45-65
High Limit	0	Hz	45-65
Delay	5	sec	1-600
Hysteresis	5	%	5-20
Relay Assignment	Off	-	Off / R1 / R2
Active Power (P)			
Low Limit	0	W	0-3000
High Limit	0	W	0-3000
Delay	5	sec	1-600
Hysteresis	5	%	5-20
Relay Assignment	Off	-	Off / R1 / R2

Alarm Settings			
Parameter	Factory Default	Unit	Setting Range / Values
Reactive Power (Q)			
Low Limit	0	VAr	0-3000
High Limit	0	VAr	0-3000
Delay	5	sec	1-600
Hysteresis	5	%	5-20
Relay Assignment	Off	-	Off / R1 / R2
Apparent Power (S)			
Low Limit	0	VA	0-3000
High Limit	0	VA	0-3000
Delay	5	sec	1-600
Hysteresis	5	%	5-20
Relay Assignment	Off	-	Off / R1 / R2
Power Factor (PF)			
Low Limit	0.00	-	0.00-1.00
High Limit	0.00	-	0.00-1.00
Delay	5	sec	1-600
Hysteresis	5	%	5-20
Relay Assignment	Off	-	Off / R1 / R2

Digital Input Settings			
Parameter	Factory Default	Unit	Setting Range / Values
Digital Input 1			
Source	Input Counter	-	Tariff / Input Counter
Delay	200	msec	100-2000
Edge	Both	-	Rise / Fall / Both
Digital Input 2			
Source	Input Counter	-	Tariff / Input Counter
Delay	200	ms	100-2000
Edge	Both	-	Rise / Fall / Both

Digital Output Settings			
Parameter	Factory Default	Unit	Setting Range / Values
Digital Output 1			
Source	Import Active Energy	-	I ACT / I REA / E ACT / E REA
Value	1	-	1-9
Multiplier	1	-	1-10(C10)- 100(C100)/ 1000(C1000)- 1/1000(B1000)- 1/100(B100)- 1/10(B10)
Duration	500	msec	30-2500
Digital Output 2			
Source	Import Reactive Energy	-	I ACT / I REA / E ACT / E REA
Value	1	-	1-9
Multiplier	1	-	1-10(C10)- 100(C100)/ 1000(C1000)- 1/1000(B1000)- 1/100(B100)- 1/10(B10)
Duration	500	msec	30-2500

Security Settings			
Parameter	Factory Default	Unit	Setting Range / Values
Activation	Off	-	Off / On
Password	000001	-	000001-999999

KLEA 5 & POWYS 6

SECTION 6
TECHNICAL
SPECIFICATIONS

TECHNICAL SPECIFICATIONS	
Supply	
Voltage	85..300V AC/DC
Frequency	45..65 Hz
Measurement Inputs	
Voltage	1..300V RMS (L-N) - 1..500V RMS (L-L)(max 700V RMS (L-L for 1 sec))
Current	0.005..6A RMS
Frequency	45..65 Hz
Relay Outputs (Optionally 2 pcs)	
Max. Switching Current	5A
Max. Switching Voltage	250 VAC
Max. Switching Power	1250 VA
Digital Input (Optionally 2 pcs)	
Input Type	Dry Contact
Digital Output (Optionally 2 pcs)	
Voltage	5..30V DC
Current	50mA
Insulation	3750V RMS
Ethernet Interface	
Port	10/100Base-TX (RJ45)
Performance	14480 pps to 10Mbps /144800 pps to 100Mbps
Over Voltage Category	
Voltage	300 V Cat III
Current	300 V Cat II
Demand	
Period	1-60 mins (Adjustable)
Ambient Conditions	
Operating Temperature	-25°C..+70°C
Storing Temperature	-30°C..+80°C
Humidity	Max. %95, no condensation
Dimensions	
Width	96 mm
Height	96 mm
Depth	45 mm
Protection Protection	
Front Side	IP54
Back Side	IP20
Power Consumption	
Power Consumption	<3VA

Measurement Accuracy				
Symbol	Measured Parameter	Class according to IEC 61557-12	Measuring Range	Other Standards
P	Total Active Power	0,5	1 % $I_n \leq I \leq I_{max}$ 0,5 Ind to 0,8 Cap	
Q	Total Reactive Power	1	2 % $I_n \leq I \leq I_{max}$ 0,25 Ind to 0,25 Cap	
S	Total Apparent Power	1	2% $I_n \leq I \leq I_{max}$	
EA	Total Active Energy	0,5	0 to 9999 MWh	IEC 62053-22 Class 1
ER	Total Reactive Energy	1	0 to 9999 MVarh	IEC 62053-23 Class 2
f	Frequency	0,2	45 - 65 Hz	
I	Current	0,5	10 % $I_n \leq I \leq I_{max}$	
IN	Neutral Current (calculated)	0,5	10 % $I_n \leq I \leq I_{max}$	
U	Voltage	0,5	$U_{min} \leq U \leq U_{max}$	
PF	Power Factor	0,2	0,5 Ind to 0,8 Cap	
THDV	Voltage total harmonic distortion	1	0 % to 20 %	
THDI	Current total harmonic distortion	1	0 % to 100 %	



Scan the QR code for all domestic and international branches.

HEADQUARTERS - FACTORY

Kızılızüm Caddesi No:15
35700 Kemalpaşa - İzmir

T: +90 232 877 08 00
F: +90 232 877 08 06

info@klemsan.com.tr
www.klemsan.com.tr

Revision No: 24102024